

Service  
Service  
Service



# Service Manual



Contents	Page	Contents	Page
1 Technical Specifications and Connection Facilities	2	MKI Mono Board: Circuit Diagram (Part 3)	25
2 Measurements Setup, Service Aid & Lead Free Requirements	4	MKI Mono Board: Circuit Diagram (Part 4)	26
3 Service Hints	8	MKI Mono Board: Circuit Diagram (Part 5)	27
4 Directions For Use	9	MKI Layout: Mono Board (Top View)	28
5 Dismantling Instructions & Service Positions	11	MKI Layout: Mono Board (Bottom View)	29
6 Service Test Program	14	MKII Mono Board: Circuit Diagram (Part 1)	30
7 Block Diagram and Wiring Diagram	17	MKII Mono Board: Circuit Diagram (Part 2)	31
Block Diagram	17	MKII Mono Board: Circuit Diagram (Part 3)	32
Wiring Diagram	18	MKII Mono Board: Circuit Diagram (Part 4)	33
8 Circuit Diagram and PWB Layout	19	MKII Mono Board: Circuit Diagram (Part 5)	34
Front: Display	19	MKII Layout: Mono Board (Top View)	35
Front: Display (Top view)	20	MKII Layout: Mono Board (Bottom View)	36
Front: Display (Bottom view)	21	PSU Circuit Diagram	37
Front: Standby	22	8 Overview - Modulator, Input/Output and Headphone/Line Output Connectors	41
Front: Standby (Top View)	22	TAS5086-5142V6REF	41
Front: Standby (Bottom View)	22	Power Output Stage (SE)	42
MKI Mono Board: Circuit Diagram (Part 1)	23	Power Output Stage (BTL)	43
MKI Mono Board: Circuit Diagram (Part 2)	24	Power Supplies	44
		Amp Board Layout : Topview	45
		Amp Board Layout : Bottomview	46
		9 Exploded View & Spare Parts List	47
		Exploded View of the set	47
		Spare Part List	48
		10 Revision List	49

This Service manual is for HTS3100/05/12/51/75/93/98 First and Second Generation models.

For First Generation model (HTS3100/05/12/51/93/98), the serial number begins with NW1A xxxx xxxx (PSCI) and VN1A xxxx xxxx (PACH).

For Second Generation model (HTS3100/05/12/51/75/93/98), the serial number begins with NW2A xxxx xxxx (PSCI) and VN2A xxxx xxxx (PACH).

©Copyright 2006 Philips Consumer Electronics B.V. Eindhoven, The Netherlands. All rights reserved. No part of this publication may be reproduced, stored in a retrieval system or transmitted, in any form or by any means, electronic, mechanical, photocopying, or otherwise without the prior permission of Philips.



## LOCATION OF PC BOARDS

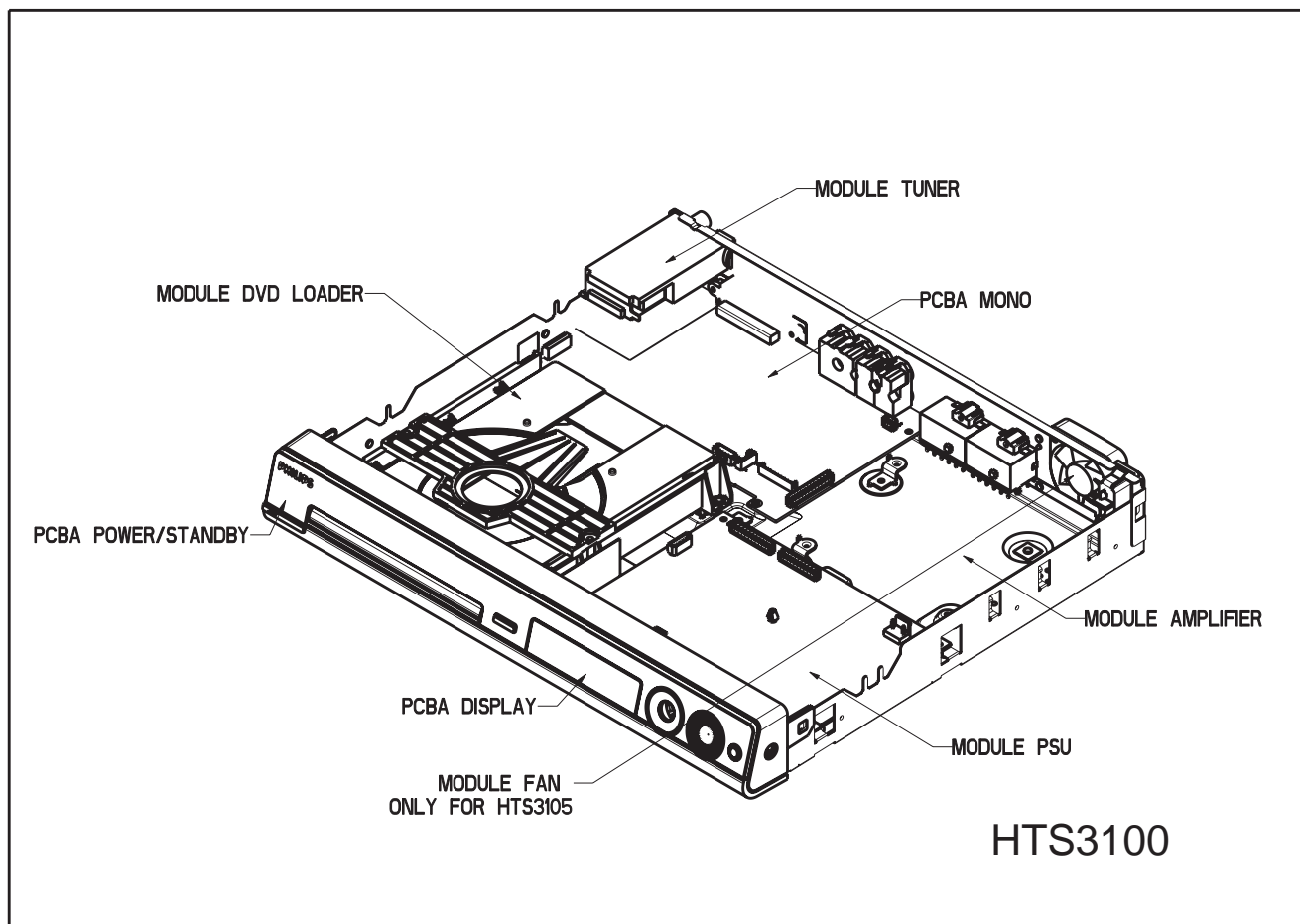

### VERSION VARIATIONS:

Features &	Type /Versions:	HTS3100					
		/05	/12	/51	/75	/93	/98
Progressive Scan		—	—	X	X	X	X
Line-Out		X	X	X	X	X	X
TV-In		—	—	X	X	X	X
Aux-In		X	X	X	X	X	X
Y/Pb/Pr (YUV) Component Video Output		—	—	X	X	X	X
CVBS		—	—	X	X	X	X
SCART		X	X	—	—	—	—

# 1. Specifications

## 1.1 General:

Mains voltage	: 230V for /05, /12, /51 120V/230V for /55 /98
Mains frequency	: 50/60Hz for /98, /55, 50Hz for /12, /05, /51
Power consumption	: 70W < 1W Eco standby power < 70W at 1/8 P <sub>rated</sub> (For main unit)
Dimension main unit	: 360 x 54 x 324mm

## 1.2 Tuner FM

Tuning range	: 87.5-108MHz
Grid	: 50kHz for /12, /05, /51 100kHz for /98, /55
IF frequency	: 10.7MHz ± 25kHz
Aerial input	: 75Ω coaxial
Sensitivity at 26dB S/N	: < 7μV
Selectivity at 600kHz bandwidth	: > 25dB
IF rejection	: > 60dB
Image rejection	: > 25dB
Distortion at RF=1mV, dev. 75kHz	: < 3%
-3dB Limiting point	: 8μV
Crosstalk at RF=1mV, dev. 67.5kHz	: > 28dB
Crosstalk at RF=1mV, dev. 40kHz	: > 18dB

## MW

Tuning range	: 531-1602kHz for /12, /05, /51, /98, /93, /55 530-1700kHz for /98, /55
Grid	: 9kHz for /12, /05, /51, /98, /55 10kHz for /98, /55
IF frequency	: 450kHz ± 1kHz
Aerial input	: Frame aerial
Sensitivity at 26dB S/N	: < 4.0mV/M
Selectivity at 18kHz bandwidth	: > 20dB
IF rejection	: > 45dB
Image rejection	: > 28dB
Distortion at RF=50mV, m=80%	: < 5%

## 1.3 AMPLIFIER:

Output power	
Front	: 25W RMS / channel
Rear	: 25W RMS / channel
Center	: 50W RMS
Subwoofer	: 50W RMS
Frequency response ±0.5dB	: 20Hz-20kHz
Hum (Volume Minimum)	: 200nW
Residual noise (Volume Minimum)	: 40nW
Input sensitivity	
Aux In	: 1V ± 3dB at 22kΩ
Scart In	: 0.5V ± 3dB at 22kΩ
Output sensitivity	
Line Out (Left/Right)	: 1V ± 2dB at 10kΩ
Scart Out (Left/Right)	: 1V ± 2dB at 10kΩ

## 1.4 COMPACT DISC/VCD/DVD:

Video Decoding	: MPEG-1/MPEG-2/ DivX 3/4/5/6 Vitra,
Video DAC	: 12 Bits
Signal System	: PAL / NTSC
Video Format	: 4:3 / 16:9

### CVBS Out <sup>1)</sup>

CVBS level	: 1.0 ± 0.1V <sub>p-p</sub>
Luminance S/N	: ≥ 60dB

### RGB/YUV Out <sup>1)</sup>

Amplitude	: 1.0 ± 0.1V <sub>p-p</sub>
S/N	: ≥ 60dB

<sup>1)</sup> Output terminals to be terminated with 75Ω

## 2. Measurements Setup, Service Aid & Lead Free Requirements

### MEASUREMENT SETUP

#### Tuner FM

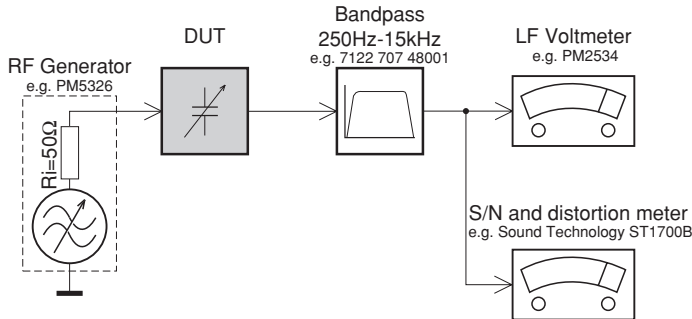

Use a bandpass filter to eliminate hum (50Hz, 100Hz) and disturbance from the pilotone (19kHz, 38kHz).

#### Tuner AM (MW,LW)

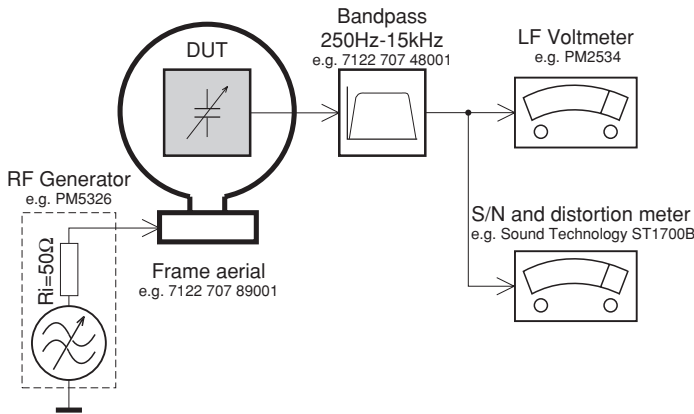

To avoid atmospheric interference all AM-measurements have to be carried out in a Faraday's cage. Use a bandpass filter (or at least a high pass filter with 250Hz) to eliminate hum (50Hz, 100Hz).

#### CD

Use Audio Signal Disc SBC429 4822 397 30184 (replaces test disc 3)

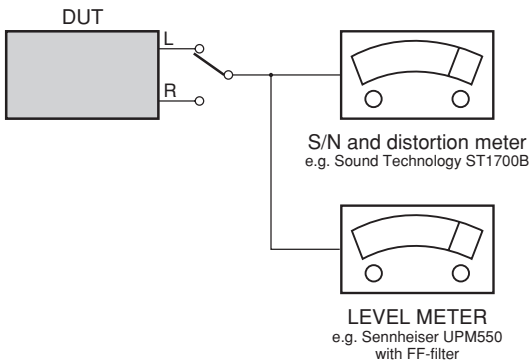

#### Recorder

Use Universal Test Cassette **CrO2** SBC419 4822 397 30069 or Universal Test Cassette **Fe** SBC420 4822 397 30071

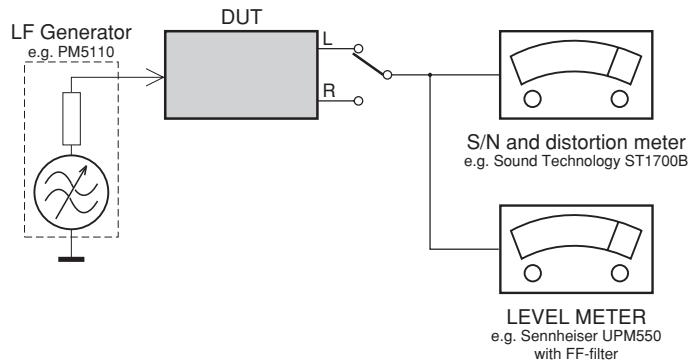



## SERVICE AIDS

### Service Tools:

Universal Torx driver holder .....	4822 395 91019
Torx bit T10 150mm .....	4822 395 50456
Torx driver set T6 - T20 .....	4822 395 50145
Torx driver T10 extended .....	4822 395 50423

### Compact Disc:

SBC426/426A Test disc 5 + 5A .....	4822 397 30096
SBC442 Audio Burn-in Test disc 1kHz .....	4822 397 30155
SBC429 Audio Signals disc .....	4822 397 30184
Dolby Pro-logic Test Disc .....	4822 395 10216

## HANDLING CHIP COMPONENTS

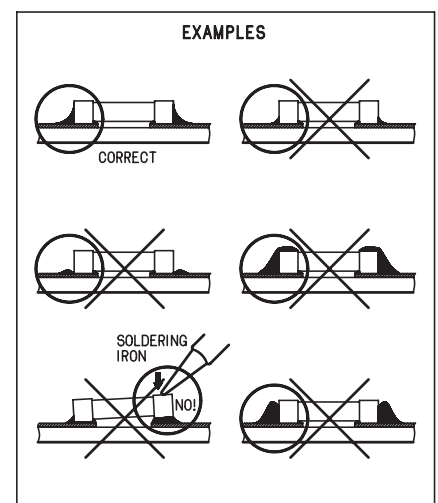
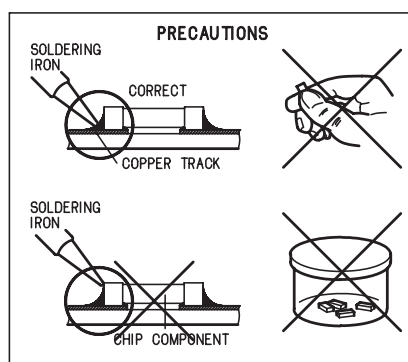
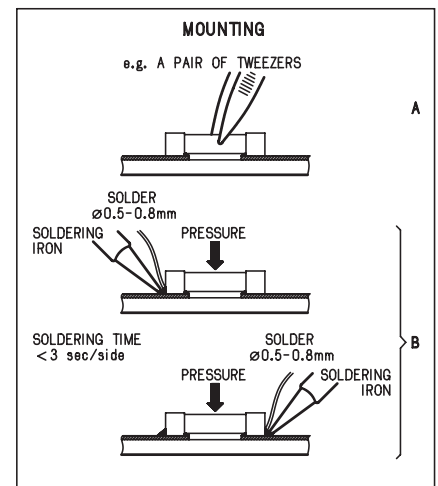
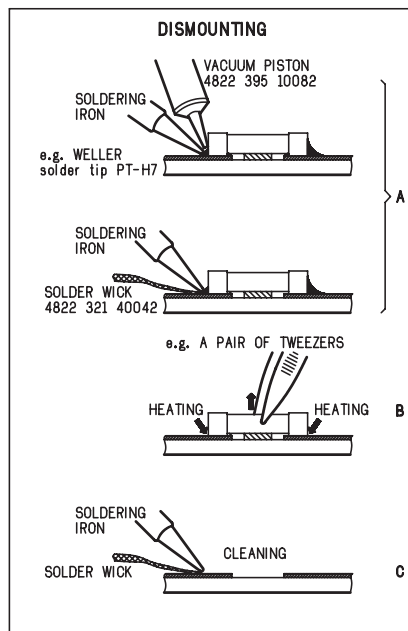
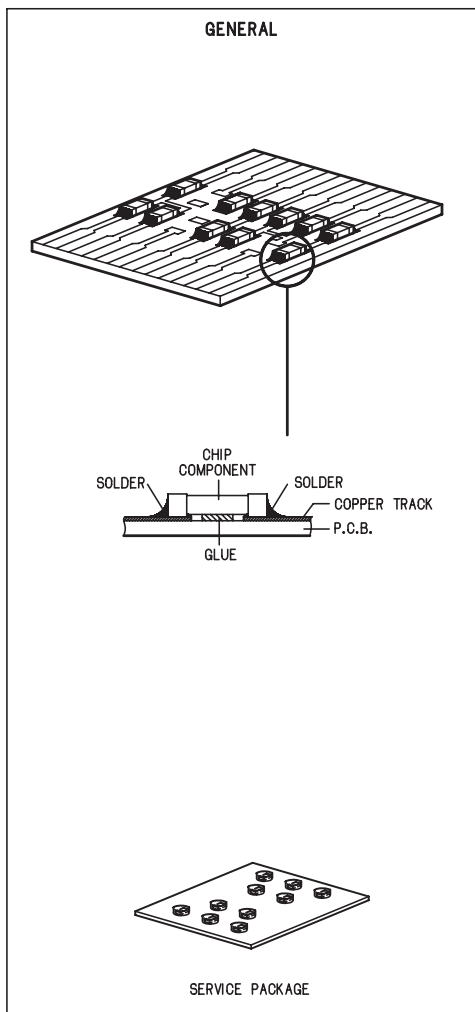

**(GB) WARNING**

All ICs and many other semi-conductors are susceptible to electrostatic discharges (ESD). Careless handling during repair can reduce life drastically.

When repairing, make sure that you are connected with the same potential as the mass of the set via a wrist wrap with resistance. Keep components and tools also at this potential.

**ESD****(NL) WAARSCHUWING**

Alle IC's en vele andere halfgeleiders zijn gevoelig voor electrostatische ontladingen (ESD). Onzorgvuldig behandelen tijdens reparatie kan de levensduur drastisch doen verminderen.

Zorg ervoor dat u tijdens reparatie via een polsband met weerstand verbonden bent met hetzelfde potentiaal als de massa van het apparaat.

Houd componenten en hulpmiddelen ook op ditzelfde potentiaal.

**(F) ATTENTION**

Tous les IC et beaucoup d'autres semi-conducteurs sont sensibles aux décharges statiques (ESD).

Leur longévité pourrait être considérablement écourtée par le fait qu'aucune précaution n'est prise à leur manipulation.

Lors de réparations, s'assurer de bien être relié au même potentiel que la masse de l'appareil et enfiler le bracelet serti d'une résistance de sécurité.

Veiller à ce que les composants ainsi que les outils que l'on utilise soient également à ce potentiel.

**(D) WARNUNG**

Alle ICs und viele andere Halbleiter sind empfindlich gegenüber elektrostatischen Entladungen (ESD).

Unvorsichtige Behandlung im Reparaturfall kann die Lebensdauer drastisch reduzieren.

Veranlassen Sie, dass Sie im Reparaturfall über ein Pulsarmband mit Widerstand verbunden sind mit dem gleichen Potential wie die Masse des Gerätes.

Bauteile und Hilfsmittel auch auf dieses gleiche Potential halten.

**(I) AVVERTIMENTO**

Tutti IC e parecchi semi-conduttori sono sensibili alle scariche statiche (ESD).

La loro longevità potrebbe essere fortemente ridotta in caso di non osservazione della più grande cauzione alla loro manipolazione.

Durante le riparazioni occorre quindi essere collegato allo stesso potenziale che quello della massa dell'apparecchio tramite un braccialetto a resistenza.

Assicurarsi che i componenti e anche gli utensili con quali si lavora siano anche a questo potenziale.

**(GB) ESD PROTECTION EQUIPMENT:**

Complete Kit ESD3 (small tablemat, wristband, connection box, extension cable and earth cable) ..... 4822 310 10671  
Wristband tester ..... 4822 344 13999

**(GB)**

Safety regulations require that the set be restored to its original condition and that parts which are identical with those specified, be used

Safety components are marked by the symbol  $\triangle$ .

**(NL)**

Veiligheidsbepalingen vereisen, dat het apparaat bij reparatie in zijn oorspronkelijke toestand wordt teruggebracht en dat onderdelen, identiek aan de gespecificeerde, worden toegepast.

De Veiligheidsonderdelen zijn aangeduid met het symbool  $\triangle$ .

**(F)**

Les normes de sécurité exigent que l'appareil soit remis à l'état d'origine et que soient utilisées les pièces de rechange identiques à celles spécifiées.

Les composants de sécurité sont marqués  $\triangle$ .

**(D)**

Bei jeder Reparatur sind die geltenden Sicherheitsvorschriften zu beachten. Der Originalzustand des Geräts darf nicht verändert werden; für Reparaturen sind Original-Ersatzteile zu verwenden.

Sicherheitsbauteile sind durch das Symbol  $\triangle$  markiert.

**(I)**

Le norme di sicurezza esigono che l'apparecchio venga rimesso nelle condizioni originali e che siano utilizzati i pezzi di ricambio identici a quelli specificati.

Componenti di sicurezza sono marcati con  $\triangle$ .

**(GB)**

After servicing and before returning set to customer perform a leakage current measurement test from all exposed metal parts to earth ground to assure no shock hazard exist. The leakage current must not exceed 0.5mA.

**(GB) Warning !**

Invisible laser radiation when open.  
Avoid direct exposure to beam.

**(S) Varning !**

Osynlig laserstrålning när apparaten är öppnad och spårren är urkopplad. Betrakta ej strålen.

**(SF) Varoitus !**

Avatussa laitteessa ja suojalukituksen ohitettaessa olet alltiina näkymättömälle laserisäteilylle. Älä katso säteeseen!

**(DK) Advarse !**

Usynlig laserstrålning ved åbning når sikkerhedsafbrydere er ude af funktion. Undgå udsættelse for strålning.

**(F)**

"Pour votre sécurité, ces documents doivent être utilisés par des spécialistes agréés, seuls habilités à réparer votre appareil en panne".

## 2.1 Lead Free Requirements

### Pb(Lead) Free Solder

When soldering , be sure to use the pb free solder.

#### IDENTIFICATION:



Regardless of special logo (not always indicated)

one must treat all sets from **1 Jan 2005** onwards, according next rules:

Important note: In fact also products of year 2004 must be treated in this way as long as you avoid mixing solder-alloys (leaded/ lead-free). So best to always use SAC305 and the higher temperatures belong to this.

Due to lead-free technology some rules have to be respected by the workshop during a repair:

- Use only lead-free solder alloy Philips SAC305 with order code 0622 149 00106. If lead-free solder-paste is required, please contact the manufacturer of your solder-equipment. In general use of solder-paste within workshops should be avoided because paste is not easy to store and to handle.
  - Use only adequate solder tools applicable for lead-free solder alloy. The solder tool must be able
    - o To reach at least a solder-temperature of 400°C,
    - o To stabilize the adjusted temperature at the solder-tip
    - o To exchange solder-tips for different applications.
  - Adjust your solder tool so that a temperature around 360°C – 380°C is reached and stabilized at the solder joint. Heating-time of the solder-joint should not exceed ~ 4 sec. Avoid temperatures above 400°C otherwise wear-out of tips will rise drastically and flux-fluid will be destroyed. To avoid wear-out of tips switch off un-used equipment, or reduce heat.
  - Mix of lead-free solder alloy / parts with leaded solder alloy / parts is possible but PHILIPS recommends strongly to avoid mixed solder alloy types (leaded and lead-free).  
If one cannot avoid or does not know whether product is lead-free, clean carefully the solder-joint from old solder alloy and re-solder with new solder alloy (SAC305).
  - Use only original spare-parts listed in the Service-Manuals. Not listed standard-material (commodities) has to be purchased at external companies.
  - Special information for BGA-ICs:
    - always use the 12nc-recognizable soldering temperature profile of the specific BGA (for de-soldering always use the lead-free temperature profile, in case of doubt)
    - lead free BGA-ICs will be delivered in so-called 'dry-packaging' (sealed pack including a silica gel pack) to protect the IC against moisture. After opening, dependent of MSL-level seen on indicator-label in the bag, the BGA-IC possibly still has to be baked dry. (MSL=Moisture Sensitivity Level). This will be communicated via AYS-website.
- Do not re-use BGAs at all.

- For sets produced before 1.1.2005 (except products of 2004), containing leaded solder-alloy and components, all needed spare-parts will be available till the end of the service-period. For repair of such sets nothing changes.

- On our website [www.atyourservice.ce.Philips.com](http://www.atyourservice.ce.Philips.com) you find more information to:

- BGA-de-/soldering (+ baking instructions)
- Heating-profiles of BGAs and other ICs used in Philips-sets

You will find this and more technical information within the "magazine", chapter "workshop news".

For additional questions please contact your local repair-helpdesk.

## 2.2 Service Hints

### CAUTION

**CHARGED CAPACITORS ON THE SERVO BOARD MAY DAMAGE THE DRIVE ELECTRONICS WHEN CONNECTING A NEW DRIVE. THAT'S WHY, BESIDES THE SAFETY MEASURES LIKE**

- SWITCH OFF POWER SUPPLY
- ESD PROTECTION

**ADDITIONAL ACTIONS MUST BE TAKEN BY THE REPAIR TECHNICIAN.**

#### The following steps have to be done when replacing the defective loader :

1. Dismantling of the loader to access the ESD protection point if necessary.
2. **Solder the ESD protection point\***.
3. Disconnect flexfoil cable from the defective loader.
4. Put a paper clip on the flexfoil to short-circuit the contacts (fig.1)
5. Replace the defective loader with a new loader.
6. Remove paperclip from the flexfoil and connect it to the new loader.
7. Remove solder joint on the ESD protection point.

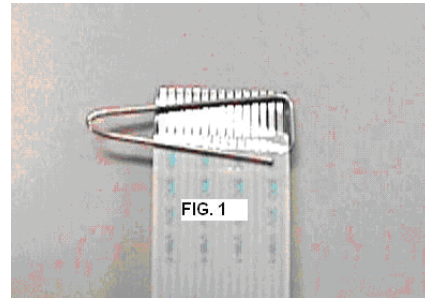
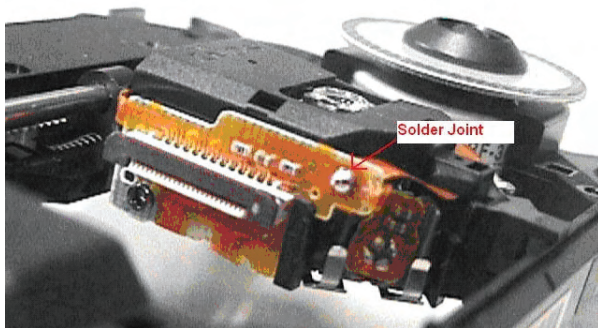

FIG. 1

ATTENTION: The laser diode of this loader is protected against ESD by a solder joint which shortcircuits the laserdiode to ground. For proper functionality of the loader this solder joint must be remove **after** connection loader to the set.

Type 1



(ESD protection point is accessible from top of loader)

Type 2

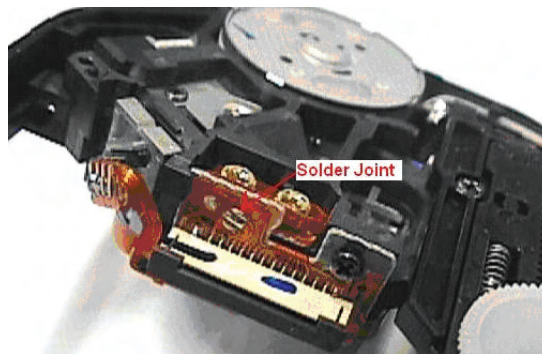

(ESD protection point is accessible from bottom of the loader)

**\*Only applicable for defective loader needed to be sent back to supplier for failure analysis and to support backcharging evidence.**

**This is also applicable for all partnership workshops.**

# 2 Set up

## D Connect the DVD system to TV

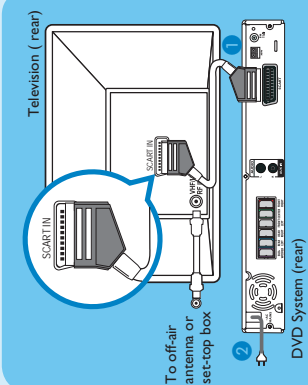

- 1 Use the supplied scart cable to connect the SCART socket on this DVD system to the SCART IN socket on your TV.
- 2 Plug in the power cable from the DVD system to an AC power outlet.

**Note** It is important to connect the DVD system directly to your TV. When watching the TV programmes, you can press **TV** on the remote control to get the sound output from the speakers system.

## E Connect the audio from other device to DVD system (optional)

Use the red and white audio cables (not supplied) to connect the AUX IN (R/L) sockets on this DVD system to the AUDIO output sockets on your Audio/Video device (for example, DVD recorder, VCR).

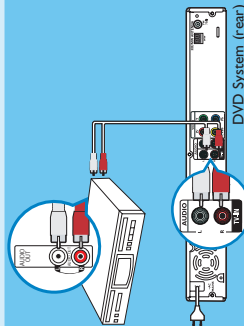

**Note** Press **AUX/ID1** on the remote control to get the sound output from the speakers system.

## A Finding the viewing channel

- 1 Press **STANDBY ON** on the DVD system.
- 2 Press **SOURCE** on the DVD system until "DISC" appears on the display panel.

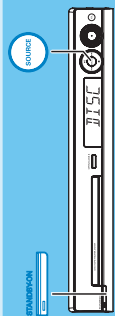

- 3 Turn on the TV. Use the TV's remote control to select the correct viewing channel for the DVD system. You should see the blue DVD background on the TV.

**Note** To search for the correct viewing channel, press the Channel Down button on the TV's remote control repeatedly (or **AV**, **SELECT**, **OK** button) until you see the blue DVD background.

## B Select the display language on the screen

- 1 Press **SETUP**. The { General Setup Page } appears.

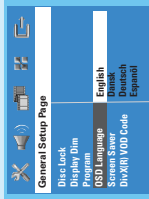

- 2 Press **▶** to select { OSD Language } and press **▶**.
- 3 Use **▶** keys to select a language option in the menu and press **OK** to confirm.
- 4 Press **SETUP** to exit.

**Note** The language set here is only for the menus that are shown on the TV while operating this DVD system, not for the DVD disc menu.

There are various setup options (Audio Setup, Video Setup, Preference Setup) available on this DVD system. Refer to the user manual for more information.

# Quick Start Guide



- 1 Connect
- 2 Set up
- 3 Enjoy

## What's in the box?

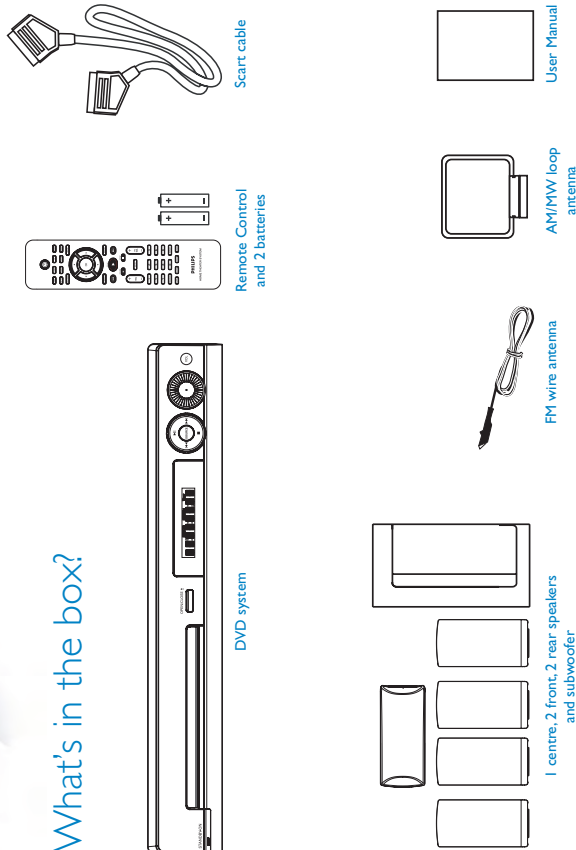



## Start disc playback

- Press **OPEN CLOSE** to open the disc tray. Load a disc and close the disc tray.

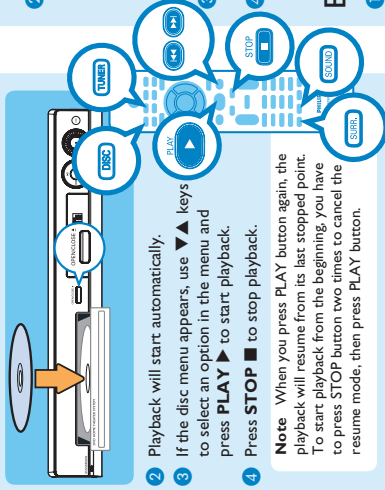

- Playback will start automatically.
- If the disc menu appears, use **▼▲** keys to select an option in the menu and press **PLAY ▶** to start playback.
- Press **STOP ■** to stop playback.

**Note** When you press **PLAY** button again, the playback will resume from its last stopped point. To start playback from the beginning, you have to press **STOP** button two times to cancel the resume mode, then press **PLAY** button.

## Listen to radio

- Press **TUNER**. The display panel will show "AUTO INSTALL PRESS PLAY".
- Press **PLAY ▶** until "START ..." appears on the display panel. All the available radio stations with strong reception signal will be stored automatically.

**Note** This feature is only available for the 1st time setup. If you wish to reinstall all the radio stations, hold down the **PROGRAM** button on the remote control.

- Once complete, use **◀▶** keys to select a preset radio station.
- To delete a preset radio station, hold down **STOP ■** until "FM/MW X DELETED" appears.

## Experience surround sound

- Press **SURR** to switch between stereo and multi-channel.
- Press **SOUND** to select either **CONCERT**, **DRAMA**, **ACTION** or **SCH-FI** preset digital sound effects.

## Troubleshooting

For more troubleshooting tips, see the user manual.

- No picture.**
- Press **DISC** button on the remote control.
  - Check the connection to the TV and ensure the plugs are firmly in place.
- No sound.**
- Adjust the volume.
  - Check the speaker connections and settings.
  - Check the audio connections and press **SOURCE** button to select the correct input source.
  - The centre and rear speakers operate only in multi-channel surround mode. Press **SURR** button to select multi-channel surround output.

- The DVD system does not work.**
- Disconnect the power cord from the power outlet for a few minutes. Reconnect the power cord and try again.

## Need help?

See the user manual that comes with your Philips DVD System

Online  
Go to [www.philips.com/support](http://www.philips.com/support)



**PHILIPS**  
2005 © Koninklijke Philips N.V.  
All rights reserved.  
12 NC 31 39 245 22291  
[www.philips.com](http://www.philips.com)

## A Finding the viewing channel

- Press **STANDBY ON** on the DVD system.
- Press **SOURCE** on the DVD system until "DISC" appears on the display panel.



- Turn on the TV. Use the TV's remote control to select the correct viewing channel for the DVD system. You should see the blue DVD background on the TV.

**Note** To search for the correct viewing channel, press the Channel Down button on the TV's remote control repeatedly (or **AV**, **SELECT**, **↵** button) until you see the blue DVD background.

## B Select the display language on the screen

- Press **SETUP**. The { General Setup Page } appears.

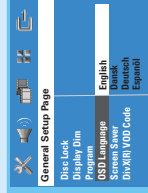

- Press **▼** to select { OSD Language } and press **▶**.
- Use **▼▲** keys to select a language option in the menu and press **OK** to confirm.
- Press **SETUP** to exit.

**Note** The language set here is only for the menus that are shown on the TV while operating this DVD system, not for the DVD disc menu.

There are various setup options (Audio Setup, Video Setup, Preference Setup) available on this DVD system. Refer to the user manual for more information.

## D Connect the DVD system to TV

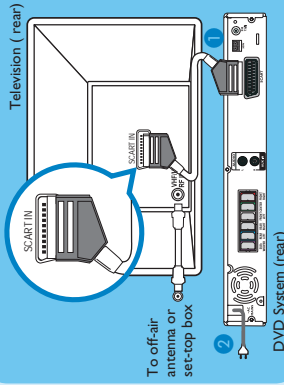

- Use the supplied start cable to connect the SCART socket on this DVD system to the SCART IN socket on your TV.
- Plug in the power cable from the DVD system to an AC power outlet.

**Note** It is important to connect the DVD system directly to your TV. When watching the TV programmes, you can press **TV** on the remote control to get the sound output from the speakers system.

## E Connect the audio from other device to DVD system (optional)

Use the red and white audio cables (not supplied) to connect the **AUX IN (R/L)** sockets on this DVD system to the **AUDIO** output sockets on your Audio/Video device (for example, DVD recorder, VCR).

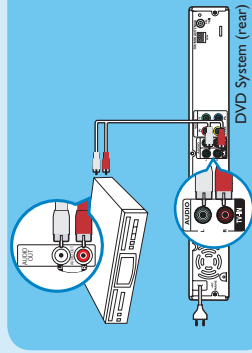

**Note** Press **AUX/DI** on the remote control to get the sound output from the speakers system.

## 4. Dismantling Instructions

### 4.1 Dismantling of the DVD Loader Tray Cover

- 1) Insert a minus screwdriver and push the lever in the direction as shown in Figure 4-1 to unlock the tray before sliding it out.



Figure 4-1

- 2) Remove the Tray Cover as shown in Figure 4-2

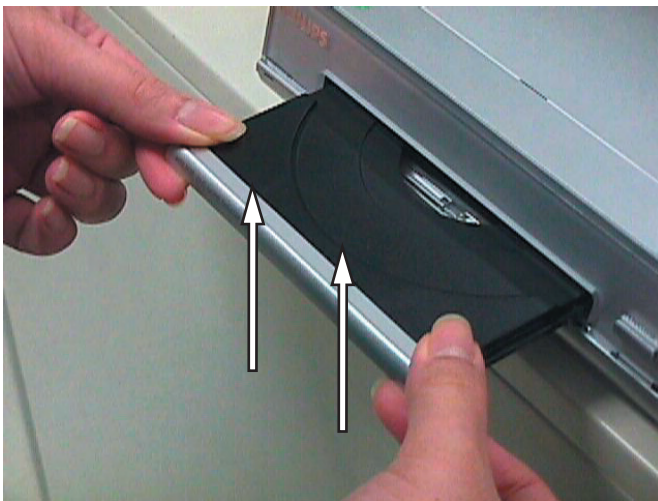

Figure 4-2

### 4.2 Dismantling of the Front Board, PSU Module & DVD Loader.

- 1) Release 4 snap hooks to remove the Front Board.
  - 1 snap hook each on the left & right side
  - 2 snap hooks on the bottom side
- 2) Loosen 4 screws A (See Figure 4-3) to remove the PSU Module.

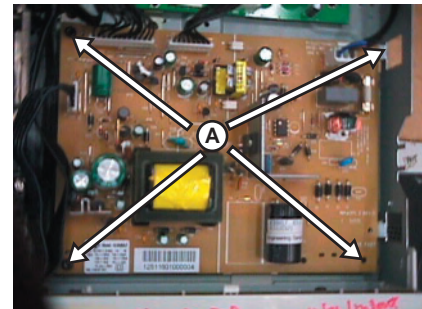

Figure 4 3

- 3) Loosen 4 screws B (See Figure 4-4) to remove the DVD Loader.

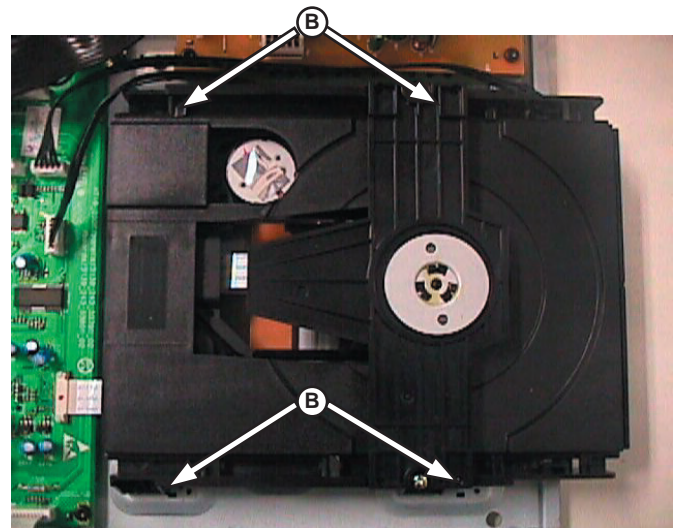

Figure 4-4



### 4.3 Dismantling of the Tuner Module & Mono Board.

- 1) Loosen 1 screw C (See Figure 4-5) to remove the Tuner Module.



Figure 4-5

- 2) Loosen 2 screws D and E (See Figure 4-6 & Figure 4-7) to remove the Mono Board.

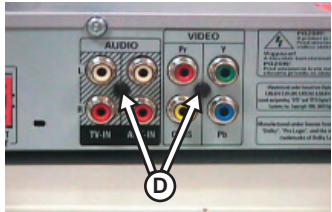

Figure 4-6(AP)

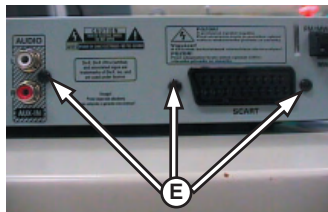

Figure 4-6(Europe)

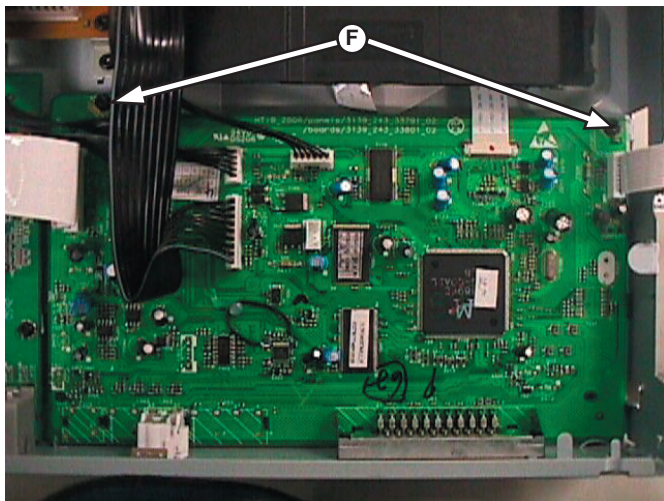

Figure 4-7

### 4.4 Dismantling of the Amp-module Board

- 1) Loosen 4 screws F and 2 screws G (See Figure 4-8 & Figure 4-9) to remove Amp-Module Board.

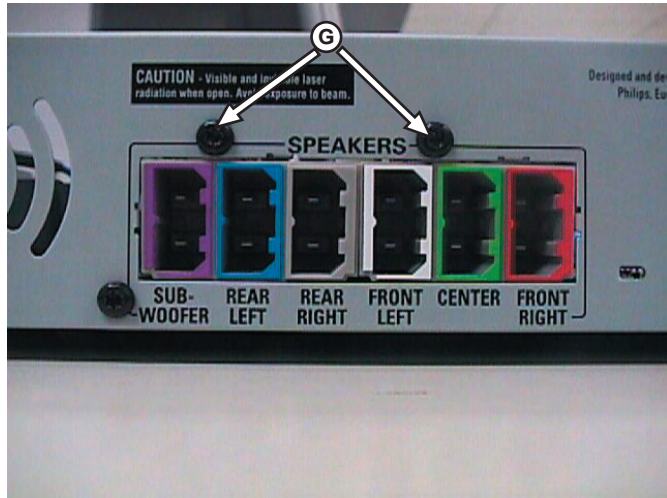

Figure 4-8

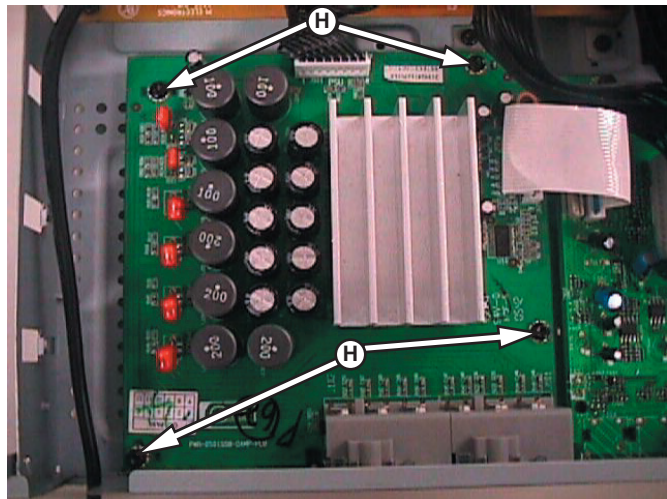
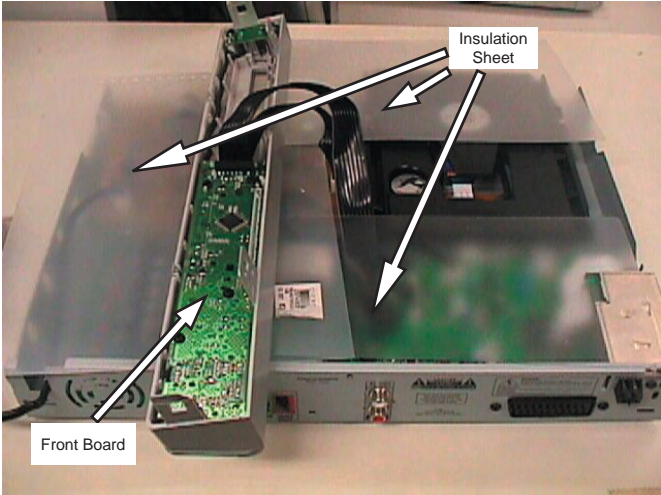

Figure 4-9



3.4 Service Positions



Service Position - Front Board

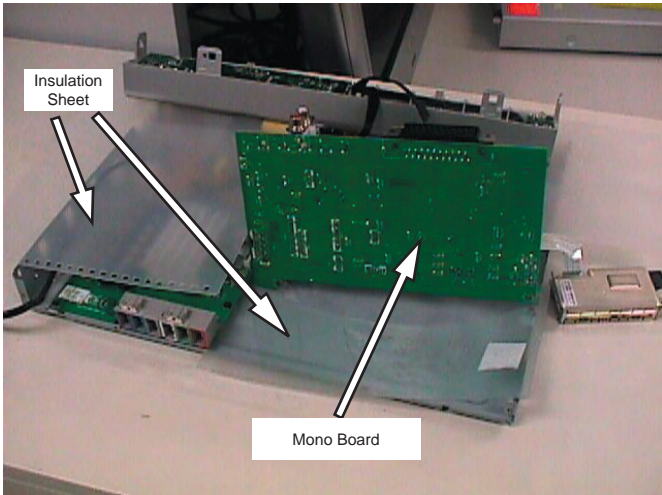

Service Position - Mono Board

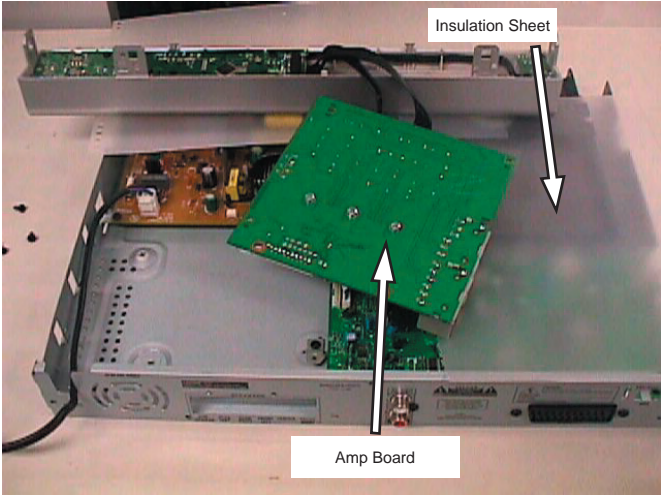

Service Position -Amp-Board

# 4. Service Test Program

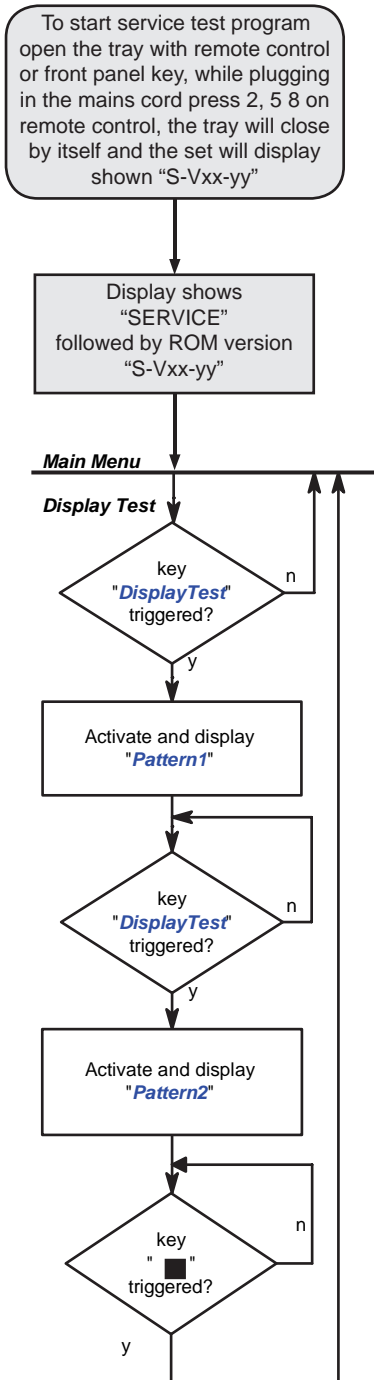

S refers to Service Mode  
 V refers to Version  
 xx refers to Software version number of BEA  
 (counting up from 01 to 99)  
 yy refers to Software version number of Front uP  
 (counting up from 01 to 99)

## 4.1 Display Test

**Purpose:**  
 This test is used to check the driving circuits, the display and whether there are any short-circuits, open-circuits or any other defects.

**Player:**  
 Following display patterns are used to test the display and its connections to μP.

Pattern 1: *Default: All display control pins are ON*  
 - to check the open-circuits



Pattern 2: *Alternate display control pins are on (Test Pattern: 0x55)*  
 - to check the short-circuits on Data port

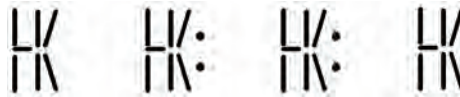

**Receiver: (HTS3100/3105):**  
 Following display patterns are used to test the display and its connections to μP.

Pattern 1: *Default: All display control pins are ON*  
 - to check the open-circuits



Pattern 2: *Alternate display control pins are on (Test Pattern: 0x55)*  
 - to check the short-circuits on Data port

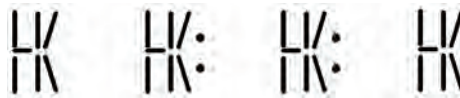

#### 4.1.1 Reprogramming of DVD version Matrix

After repair, the customer setting and region code may be lost. Reprogramming will put the set back in the state in which it has left the factory, ie. with the default setting and the allowed region code.

Model	Region	Region Code	TV Type
HTS 3100/12	Europe	2	PAL
HTS 3100/51	Russia	5	PAL
HTS 3100/05	UK, Ireland	2	PAL
HTS 3100/75	Aust/NZ	4	PAL
HTS 3100/98	APAC	3	PAL
HTS 3100/93	China	6	PAL

To reprogram do as follows:

- Power up the set and select DISC source.
- Open tray by press "OPEN/CLOSE" button on the set or press and hold "STOP" button on the RC.
- Press the following buttons on the Remote Control:
  - <9> <9> <9> <9> <AUDIO> <0> .....for HTS 3100/12
  - <9> <9> <9> <9> <AUDIO> <1> .....for HTS 3100/51
  - <9> <9> <9> <9> <AUDIO> <2> .....for HTS 3100/05
  - <9> <9> <9> <9> <AUDIO> <7> .....for HTS 3100/75
  - <9> <9> <9> <9> <AUDIO> <4> .....for HTS 3100/98
  - <9> <9> <9> <9> <AUDIO> <6> .....for HTS 3100/93
- The display shows 'YYYY-ZZ' and the tray will close.
  - YYYY = model number (eg. 8300, 8500, etc.)
  - ZZ = slash stroke version (eg. 01, 69, etc.)

#### 4.1.2 Procedure for check Software version

- Power up the set and select DISC source.
- Open tray by press "OPEN/CLOSE" button on the set or press and hold "STOP" button on the RC.
- Press "DISPLAY" button on the Remote control.
- The TV screen will shows:

PPPP-Vxx YYYYY-ZZ  
SERVO: GGGGGGGG REG:DD

PPPP = HTS 3300MKII  
xx = version number  
YYYYY = model # - 3300D  
ZZ = stroke version (12, 51, 05, 98, 55, 51K)  
GGGGGGGG = version for servo code

#### 4.1.3 Burning of firmware

- Unzip the zip-archive attached with this service information.
- Start the CD burning software and create a new CD Project (Data disc) with the following settings:
  - File System: ISO9660
  - Format: MODE 2/XA
  - Recording format: Single Session (Track at once), Finalized CD
- Place the content of the zip-archive into the root directory of the new CD project.
- Burn the data onto a blank CDR or CDRW.

Note: ISO9660 is mandatory, UDF discs are not supported!  
The final CDROM must not contain any other data except the file from the zip-archive.

#### 4.1.4 Procedure to upgrade the firmware

- Power up the set and open tray.
- Insert the prepared Upgrade CDROM and close the tray.
- The set will display:

LOAD -> MULTICH -> ..... ->UPG END.  
The whole process takes less than 2 minutes.

*Note: Do not press any button or interrupt the main supply upgrading process, Otherwise the set may become defective.*

- When the upgrade is completed, the tray will close automatic.
- The tray will close and the set will go to Standby mode automatically when the upgrade process is completed.

#### 4.1.5 Procedure to check the firmware version to confirm upgrading

- Power up the set and open tray.
- Press the <Menu Display> button on the Remote Control.
- The firmware version will be displayed on the top left hand corner of the OSD.

#### 4.1.6 Trade Mode

Trade mode is a feature that will block all set keys when enabled. It is for dealers to prevent customers from removing disc, changing source etc using the set keys. Rotary and Remote Control (RC) keys are still allowed in Trade mode.

##### To activate Trade Mode:

- Power up the set and select DISC source.
- Open tray by press "OPEN/CLOSE" button on the set or press and hold "STOP" button on the RC.
- Then press buttons <2> <5> <9> on the RC.
- The display shows 'TRA ON' and the tray will close. Trade Mode is now enabled.

##### To deactivate Trade Mode:

- Power up the set and select DISC source.
- Open tray by press and hold "STOP" button on the RC.
- Then press buttons <2> <5> <9> on the RC.
- The display shows 'TRA OFF' and the tray will close. Trade Mode is now disabled.

#### 4.1.7 Procedure to change Tuner Grid (/98, /55 only)

- Press **SOURCE** to select "FM" or "TW".
- Press **STANDBY ON** to switch the DVD system to standby mode.
- Press **STANDBY ON** again to turn on the DVD system and hold down **◀◀** button on the front panel.  
→ The display will show "GRID 9" or "GRID 10".

##### Helpful Hint:

– GRID 9 and GRID 10 indicate that the tuning grid is in step of 9 kHz and 10 kHz respectively.

*Note: Repeating the same action will toggle back to its previous tuning grid setting.*

**Notes:**

# Block Diagram

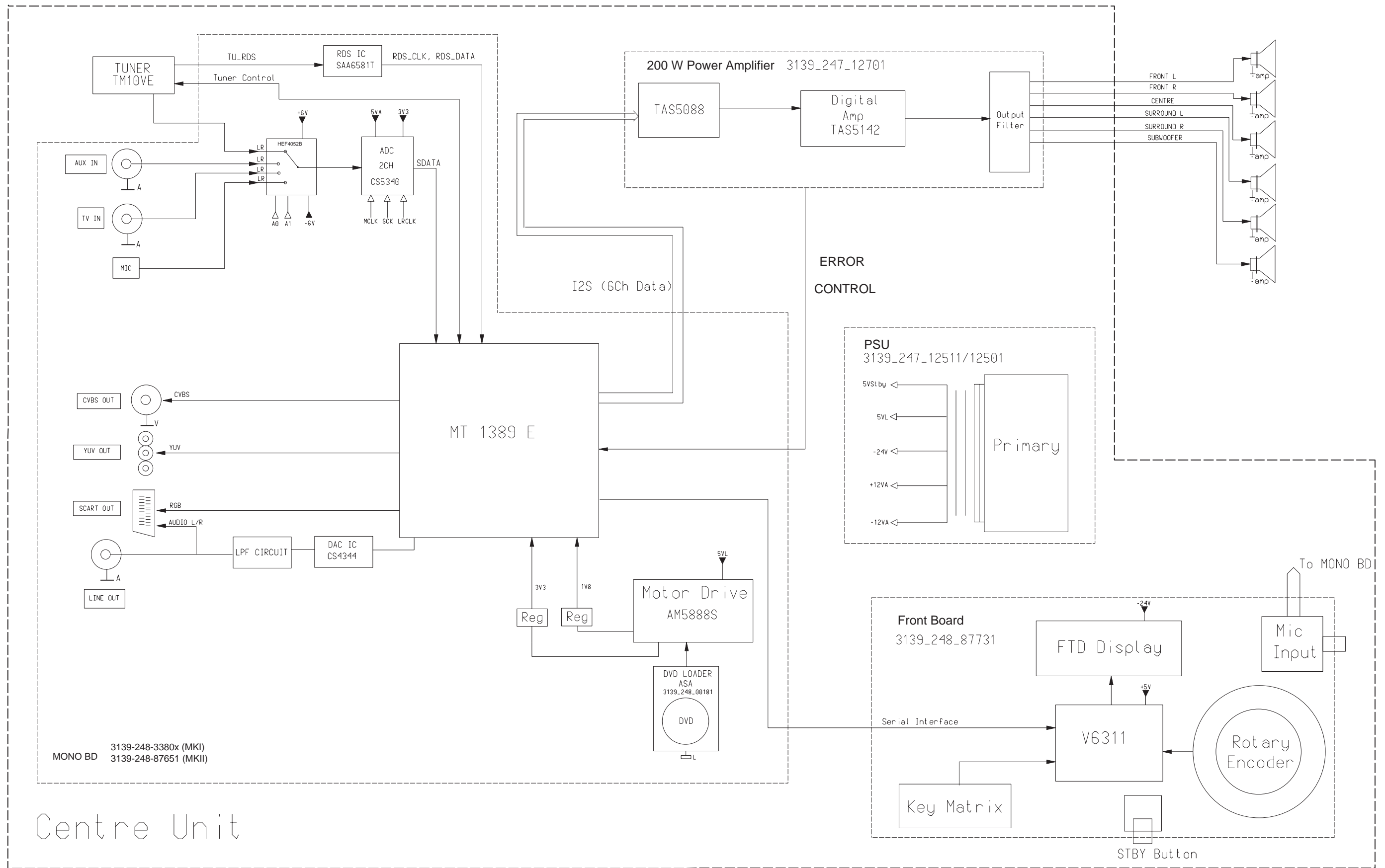

3139-248-3380x (MKI)  
MONO BD 3139-248-87651 (MKII)

Centre Unit



Front: Display

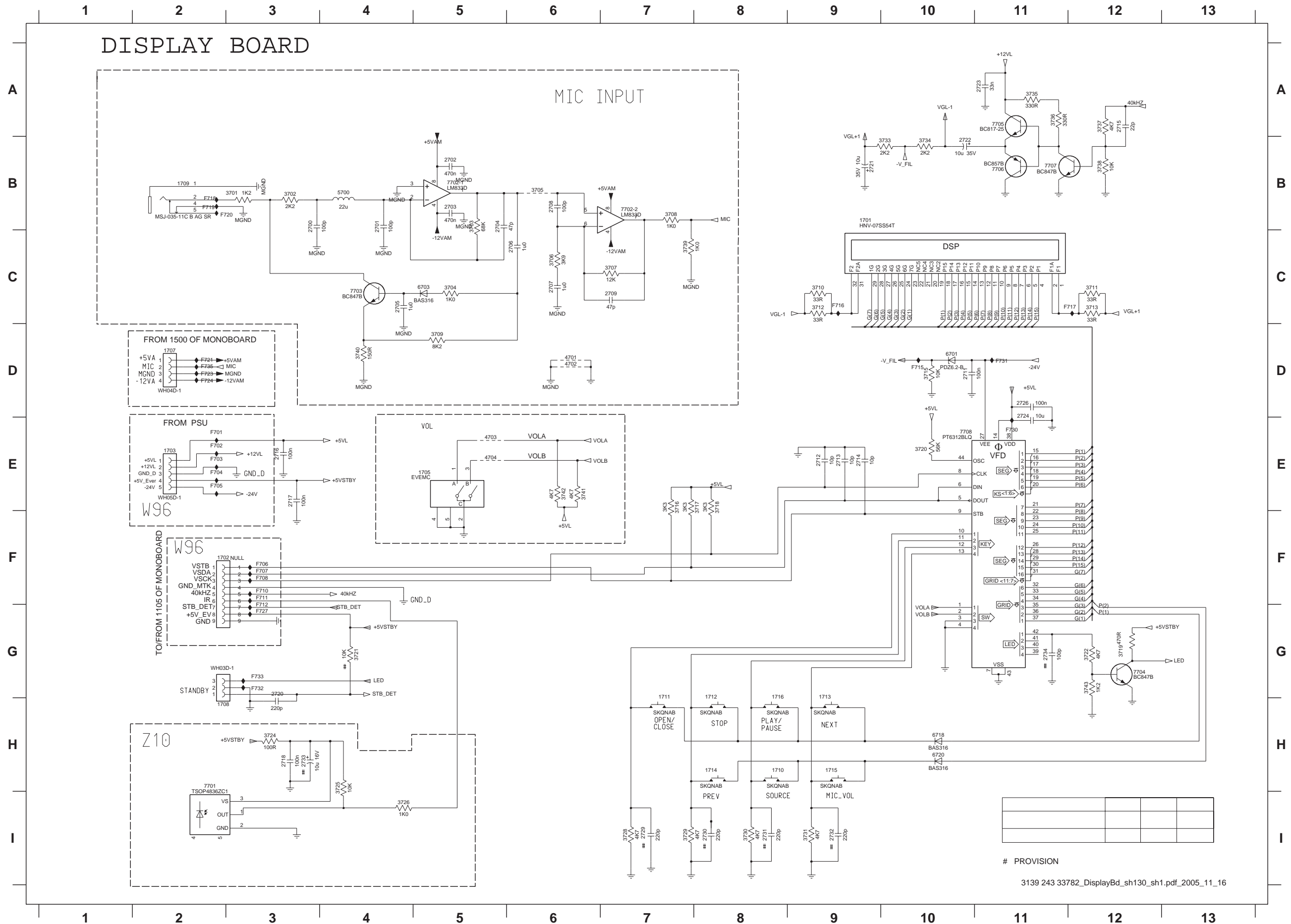

- 1701 B9
- 1702 F2
- 1703 E2
- 1705 E5
- 1707 D2
- 1708 H2
- 1709 B2
- 1710 H8
- 1711 H7
- 1712 H8
- 1713 H9
- 1714 H8
- 1715 H9
- 1716 H8
- 1700 B3
- 2701 B4
- 2702 B5
- 2703 B5
- 2704 B5
- 2705 C4
- 2706 C6
- 2708 B6
- 2709 C7
- 2711 D10
- 2712 E9
- 2713 E9
- 2714 E9
- 2715 A12
- 2716 E3
- 2717 E3
- 2718 H3
- 2720 G3
- 2721 B9
- 2722 B10
- 2723 A11
- 2724 E11
- 2726 D11
- 2729 I7
- 2730 I8
- 2731 I8
- 2732 I9
- 2733 H3
- 2734 G11
- 3701 B3
- 3702 B3
- 3703 B5
- 3704 C5
- 3705 B6
- 3706 C6
- 3707 C7
- 3708 B7
- 3709 D5
- 3710 C9
- 3711 C2
- 3712 C9
- 3713 C9
- 3715 D10
- 3716 E7
- 3717 E8
- 3718 E8
- 3719 G12
- 3720 E10
- 3721 G4
- 3722 G12
- 3724 H3
- 3725 H4
- 3726 I4
- 3728 I7
- 3729 I7
- 3730 I8
- 3731 I9
- 3733 B10
- 3734 B10
- 3735 A11
- 3736 A11
- 3737 A12
- 3738 B12
- 3739 C7
- 3740 D4
- 3741 E6
- 3742 E6
- 3743 G12
- 4701 D6
- 4702 D6
- 4703 E5
- 4704 E5
- 5700 B4
- 6701 D10
- 6703 C5
- 6718 H10
- 6720 H10
- 7701 H2
- 7702-1 B5
- 7702-2 B7
- 7703 C4
- 7704 G12
- 7705 A11
- 7706 B11
- 7707 B11
- 7708 E10
- F701 E2
- F702 E2
- F703 E2
- F704 E2
- F705 E2
- F706 F3
- F707 F3
- F708 F3
- F710 F3
- F711 F3
- F712 G3
- F713 G3
- F714 G3
- F715 G3
- F716 G3
- F717 G3
- F718 G3
- F719 G3
- F720 G3
- F721 G3
- F722 G3
- F723 G3
- F724 G3
- F725 G3
- F726 G3
- F727 G3
- F728 G3
- F729 G3
- F730 G3
- F731 G3
- F732 G3
- F733 G3
- F734 G3
- F735 G3
- F736 G3
- F737 G3
- F738 G3
- F739 G3
- F740 G3
- F741 G3
- F742 G3
- F743 G3
- F744 G3
- F745 G3
- F746 G3
- F747 G3
- F748 G3
- F749 G3
- F750 G3
- F751 G3
- F752 G3
- F753 G3
- F754 G3
- F755 G3
- F756 G3
- F757 G3
- F758 G3
- F759 G3
- F760 G3
- F761 G3
- F762 G3
- F763 G3
- F764 G3
- F765 G3
- F766 G3
- F767 G3
- F768 G3
- F769 G3
- F770 G3
- F771 G3
- F772 G3
- F773 G3
- F774 G3
- F775 G3
- F776 G3
- F777 G3
- F778 G3
- F779 G3
- F780 G3
- F781 G3
- F782 G3
- F783 G3
- F784 G3
- F785 G3
- F786 G3
- F787 G3
- F788 G3
- F789 G3
- F790 G3
- F791 G3
- F792 G3
- F793 G3
- F794 G3
- F795 G3
- F796 G3
- F797 G3
- F798 G3
- F799 G3
- F800 G3

# PROVISION

3139 243 33782\_DisplayBd\_sh130\_sh1.pdf\_2005\_11\_16







Front: Display (Bottom view)

2700	A1	2707	A2	2715	A6	2726	A10	3702	B1	3709	B1	3717	A8	3725	B6	3734	A7	3741	A8	5700	A1	7704	A11
2701	B2	2708	A2	2716	A10	2729	B12	3703	B1	3710	B7	3718	A8	3726	B6	3735	A6	3742	A8	6701	A7	7705	A7
2702	A2	2709	A2	2717	A11	2730	A5	3704	B1	3711	B10	3719	A11	3728	B12	3736	A6	3743	A10	6703	B1	7706	A6
2703	B2	2711	A7	2718	B6	2731	A4	3705	A2	3712	B7	3720	A10	3729	A5	3737	A6	4701	A2	6718	B8	7707	A6
2704	B1	2712	A8	2720	A11	2732	A3	3706	A2	3713	B10	3721	A11	3730	A4	3738	A6	4702	A1	6720	B8	7708	A9
2705	B1	2713	A8	2723	A5	2734	A10	3707	A2	3715	A7	3722	A10	3731	A3	3739	A2	4703	A2	7702	B2		
2706	B1	2714	A8	2724	A10	3701	A1	3708	A2	3716	A8	3724	B5	3733	A7	3740	B1	4704	A2	7703	B1		

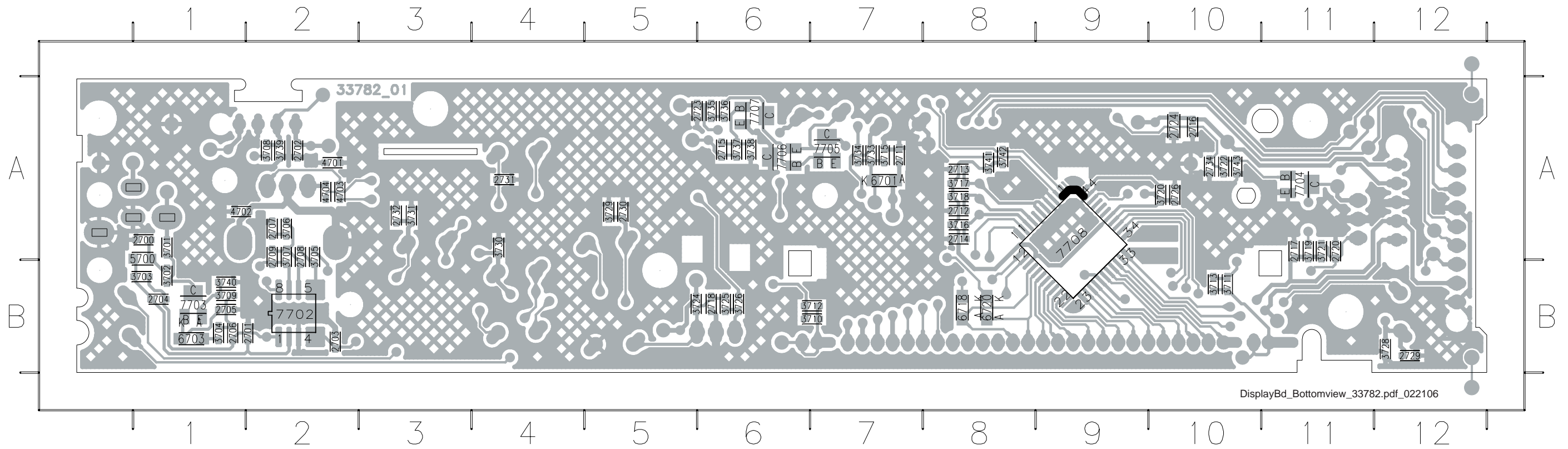

Front: Standby

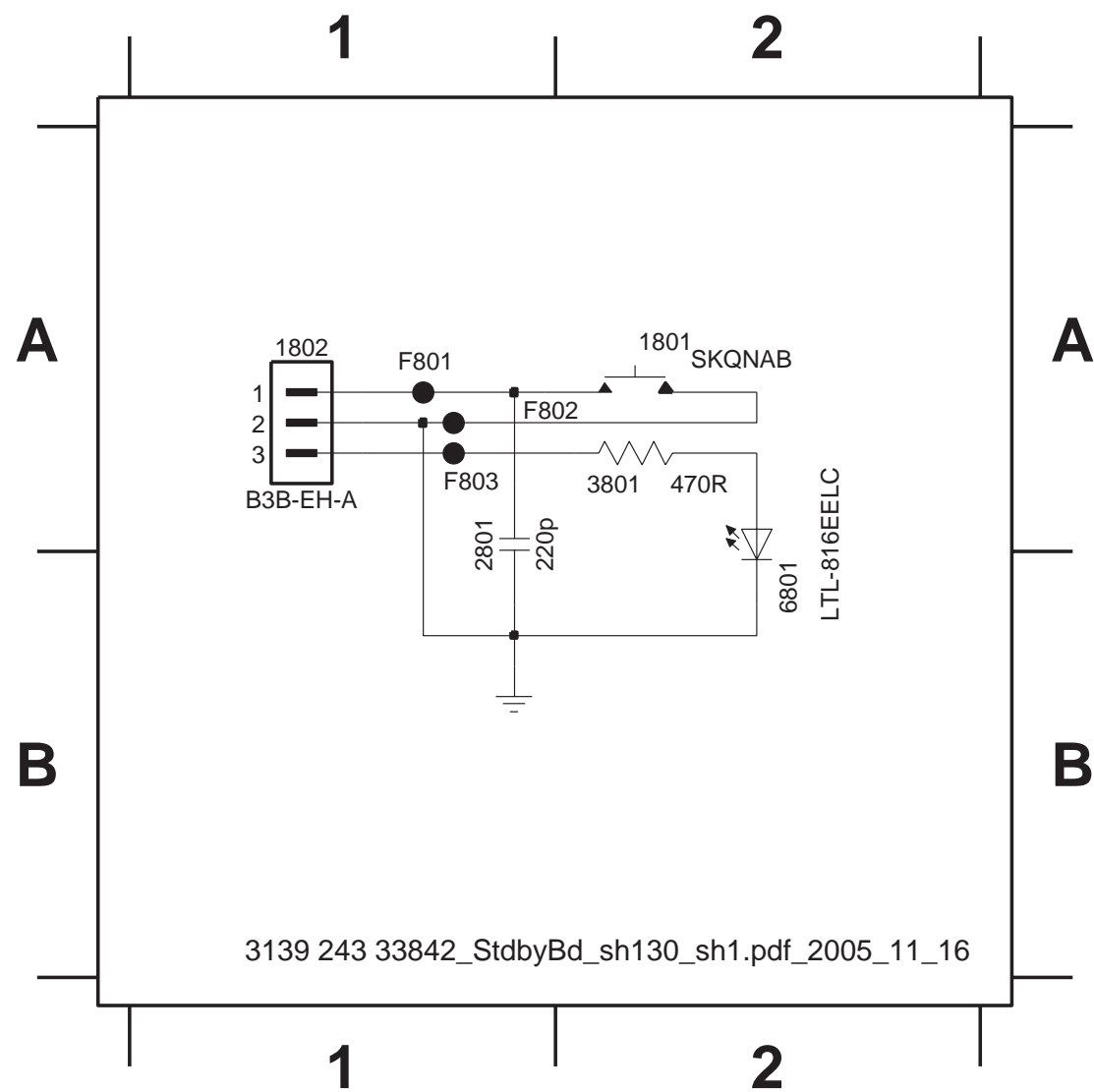

Front: Standby (Top View)

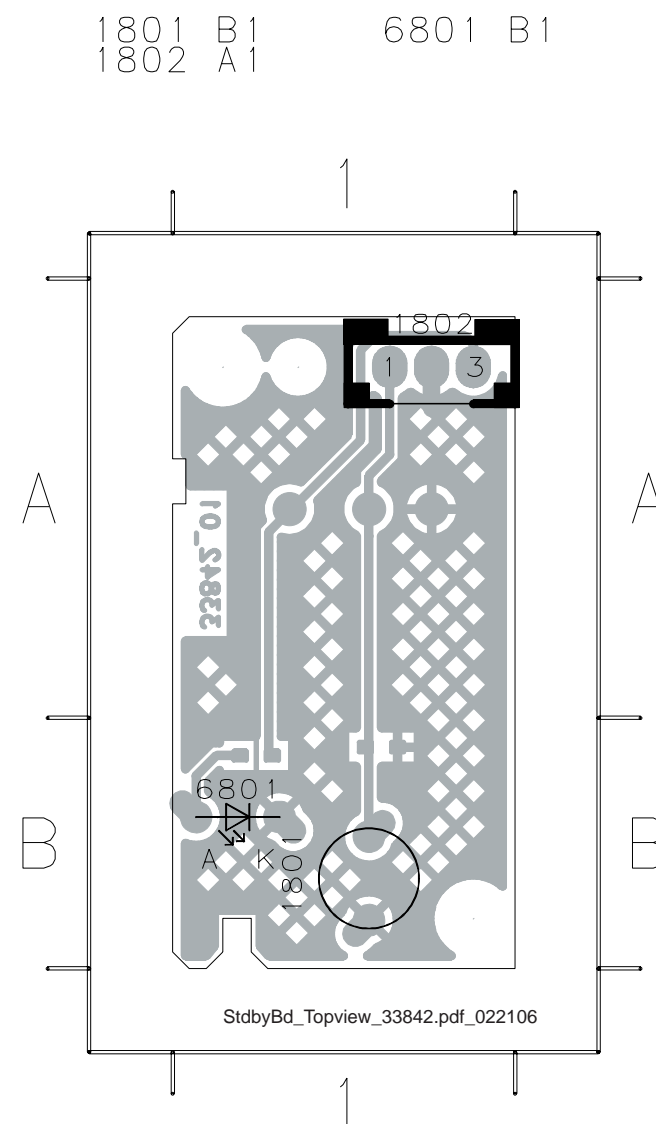

Front: Standby (Bottom View)

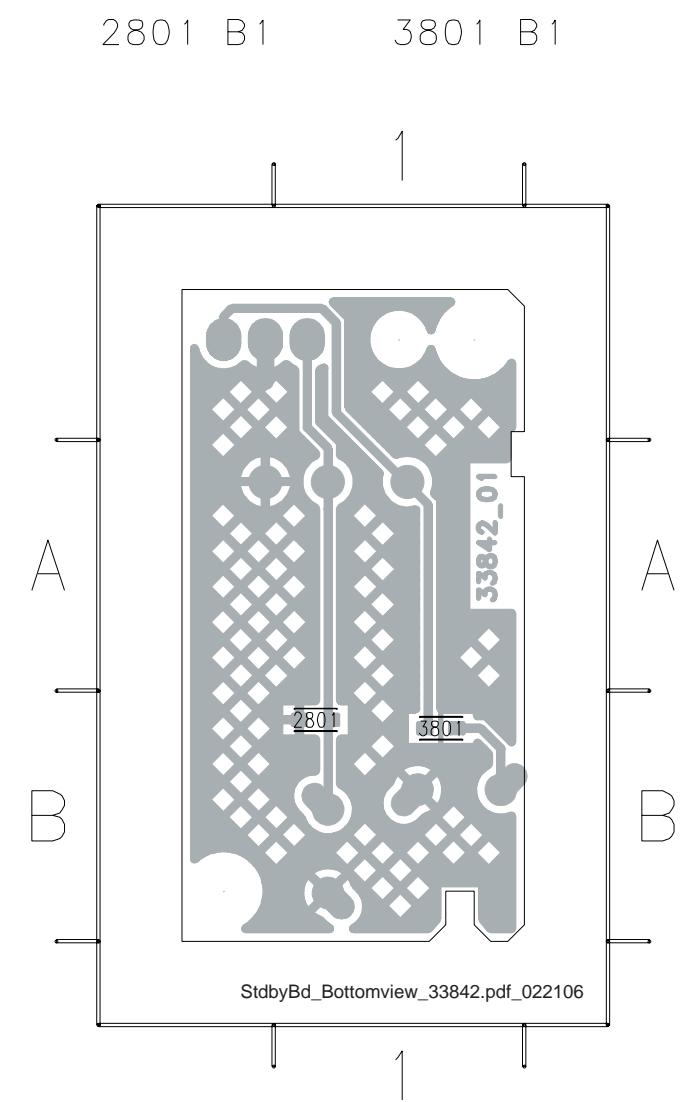

# Mono Board: Circuit Diagram MKI (Part 1)

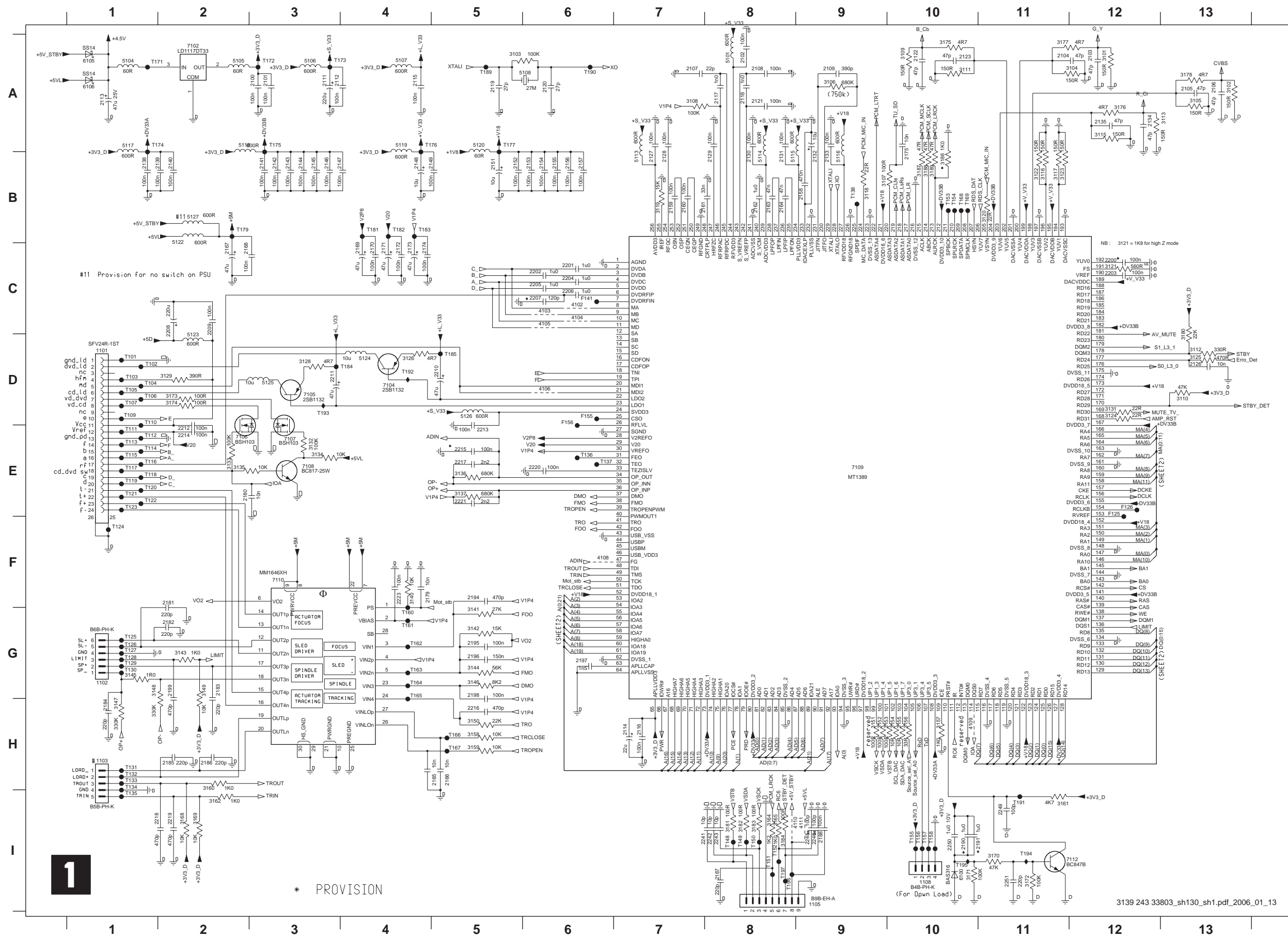

1101 D1	2241 I7	6100 I10
1102 G1	2242 I8	6105 A1
1103 H1	2243 I8	6106 A1
1105 I9	2245 I9	7102 A2
1108 I10	2246 I9	7104 D4
2100 A3	2249 I11	7105 D3
2101 A3	2250 I10	7106 E2
2102 A8	2251 I11	7107 E3
2103 A12	3101 A12	7108 E3
2104 A11	3102 A13	7109 B3
2105 A13	3103 A5	7110 F3
2106 A13	3104 A12	7112 I11
2107 A7	3105 A13	F125 E12
2108 A8	3106 A9	F126 E12
2109 A9	3107 B9	F141 C6
2111 A3	3108 A7	F155 D6
2112 A3	3109 A10	F156 D6
2113 A1	3110 D13	T101 D1
2114 H7	3111 A10	T102 D1
2115 A4	3112 D13	T103 D1
2116 H7	3113 A13	T104 D1
2117 A8	3115 A12	T105 D1
2118 A8	3116 B11	T106 D1
2119 A5	3117 B11	T107 D1
2120 A6	3118 B9	T109 D1
2121 A8	3119 B7	T110 D1
2122 A10	3120 B11	T111 E1
2123 A10	3121 C12	T112 E1
2126 D13	3122 B11	T113 E1
2127 B7	3123 B11	T114 E1
2128 B7	3124 D12	T115 E1
2129 B8	3125 D13	T116 E1
2130 B8	3126 D4	T117 E1
2131 B8	3128 D3	T118 E1
2132 B9	3129 D2	T119 E1
2133 B9	3131 D12	T120 E1
2134 A12	3132 E3	T121 E1
2135 A12	3133 E2	T122 E1
2138 B1	3134 E3	T123 E1
2139 B2	3135 E2	T124 F1
2140 B2	3136 E5	T125 G1
2141 B3	3137 E5	T126 G1
2142 B3	3140 F4	T127 G1
2143 B3	3141 G5	T128 G1
2144 B3	3142 G5	T129 G1
2145 B3	3143 G2	T130 G1
2146 B3	3144 G5	T131 H1
2147 B4	3145 G1	T132 H1
2148 B4	3146 G5	T133 H1
2149 B5	3147 H1	T134 H1
2151 B5	3148 G1	T135 I1
2152 B5	3149 G2	T136 E6
2153 B6	3150 H5	T137 E6
2154 B6	3151 H9	T138 B9
2155 B6	3152 H9	T148 I8
2156 B6	3153 H9	T149 I8
2157 B6	3154 H10	T150 I8
2158 B9	3155 H10	T151 I8
2159 B7	3156 H10	T152 I8
2160 B7	3157 H10	T153 B10
2161 B7	3158 H5	T154 B10
2162 B8	3159 H5	T155 I10
2163 B8	3160 H2	T156 I10
2164 B8	3161 H1	T157 I10
2165 H5	3162 I2	T158 I10
2166 H5	3164 I2	T160 G4
2167 C2	3165 I8	T161 G4
2168 C2	3168 I2	T162 G4
2169 C4	3169 I2	T163 G4
2170 C4	3170 I11	T164 G4
2171 C4	3171 I10	T165 G4
2172 C4	3172 I11	T166 H5
2173 C4	3173 D2	T167 H5
2174 C4	3174 D2	T168 B10
2175 B10	3175 A10	T169 B10
2179 F4	3176 A12	T171 A1
2180 E2	3177 A11	T172 A3
2181 F2	3178 A13	T173 A3
2182 G2	3180 D13	T174 A1
2183 G2	3181 I8	T175 A3
2184 H1	3182 I8	T176 A4
2185 H2	3183 I8	T177 A5
2186 H2	3184 I8	T179 B2
2187 I8	3186 B10	T181 B4
2188 I9	3187 B10	T182 B4
2190 I10	3188 B10	T183 B4
2191 I11	3189 B10	T184 D4
2194 F5	4102 C6	T185 D5
2195 G5	4103 C6	T189 A5
2196 G5	4104 C6	T190 A6
2197 G6	4105 C6	T191 I11
2198 G5	4106 D6	T192 D4
2199 G2	4108 F6	T193 D3
2200 C12	4109 H10	T194 I11
2201 C6	4110 I9	T195 I10
2202 C6	4111 I9	T196 I8
2203 C12	5101 A8	T197 I8
2204 C6	5104 A1	
2205 C6	5105 A2	
2206 C6	5106 A3	
2207 C6	5107 A4	
2208 C2	5108 A6	
2209 C2	5113 B8	
2210 D5	5114 B7	
2211 D3	5115 B9	
2212 E2	5116 B9	
2213 E5	5117 A1	
2214 E2	5118 A2	
2215 E5	5119 A4	
2216 H5	5120 A5	
2217 E5	5122 C2	
2218 I2	5123 D4	
2219 I2	5124 D4	
2220 E6	5125 D3	
2221 E5	5126 D5	
2223 F4	5127 B2	

# Mono Board: Circuit Diagram MKI (Part 2)

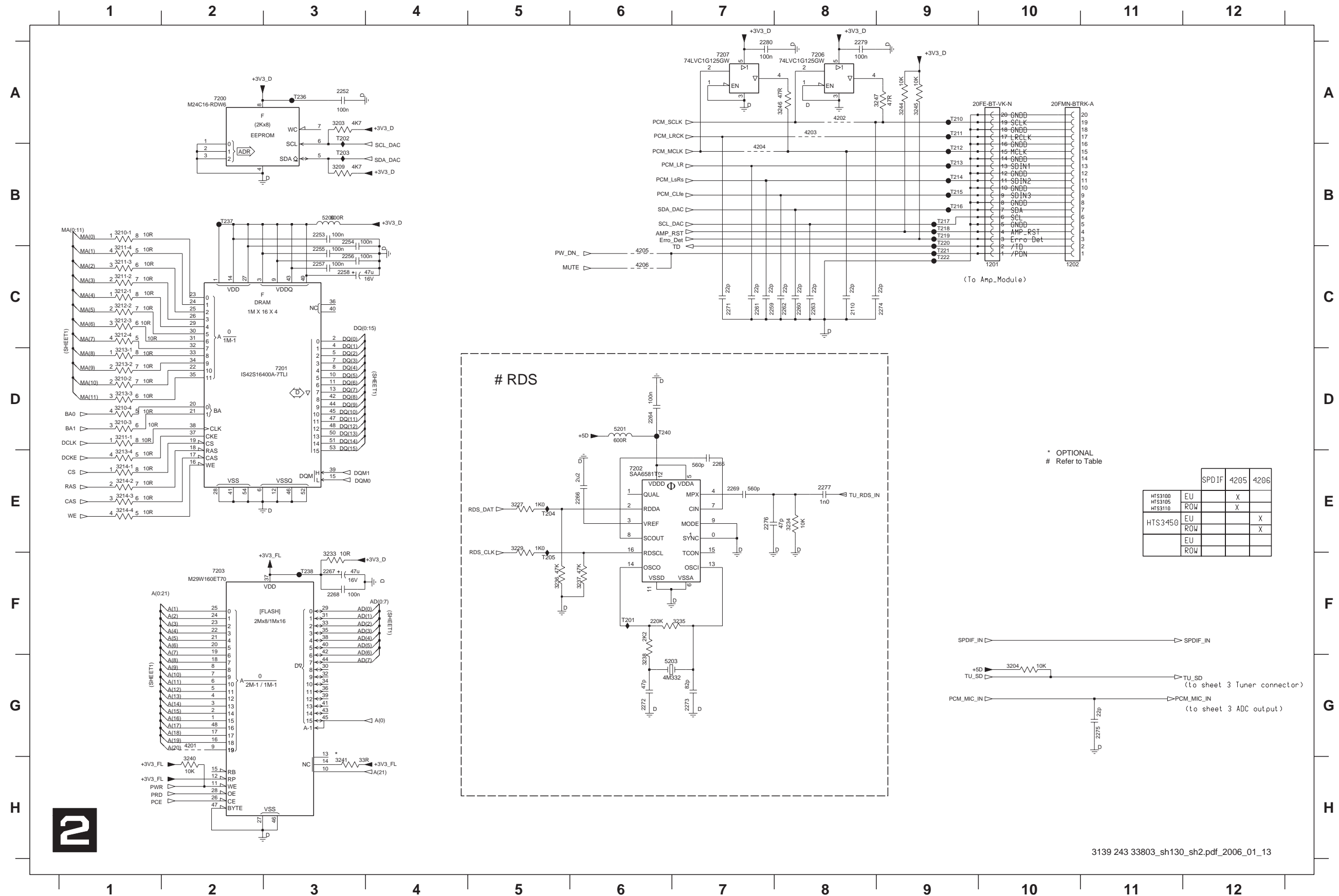

- 1201 C10
- 1202 C10
- 1210 C8
- 2252 A3
- 2253 B3
- 2254 B3
- 2255 C3
- 2256 C3
- 2257 C3
- 2258 C3
- 2259 C7
- 2260 C8
- 2261 C7
- 2262 C8
- 2263 C8
- 2264 D6
- 2265 E7
- 2266 E6
- 2267 F3
- 2268 F3
- 2269 E7
- 2271 C7
- 2272 G6
- 2273 G7
- 2274 C9
- 2275 G11
- 2276 E7
- 2277 E8
- 2279 A8
- 2280 A7
- 3203 A3
- 3204 B3
- 3209 B3
- 3210-1 B1
- 3210-2 D1
- 3210-3 D1
- 3210-4 D1
- 3211-1 C1
- 3211-2 C1
- 3211-3 C1
- 3211-4 C1
- 3212-1 C1
- 3212-2 C1
- 3212-3 C1
- 3212-4 C1
- 3213-1 D1
- 3213-2 D1
- 3213-3 D1
- 3213-4 E1
- 3214-1 E1
- 3214-2 E1
- 3214-3 E1
- 3214-4 E1
- 3227 E5
- 3229 E5
- 3233 F3
- 3234 E8
- 3235 F7
- 3236 F5
- 3237 F6
- 3238 G6
- 3240 H2
- 3241 H3
- 3244 A9
- 3245 A9
- 3246 A8
- 3247 A9
- 4201 G2
- 4202 A8
- 4203 A8
- 4204 B7
- 4205 C6
- 4206 C6
- 5200 B3
- 5201 D6
- 5203 G6
- 7200 A2
- 7201 D3
- 7202 E6
- 7203 F2
- 7206 A8
- 7207 A7
- T201 F6
- T202 A3
- T203 B3
- T204 E5
- T205 F5
- T210 A9
- T211 A9
- T212 B9
- T213 B9
- T214 B9
- T215 B9
- T216 B9
- T217 B9
- T218 B9
- T219 B9
- T220 B9
- T221 C9
- T222 C9
- T236 A3
- T237 B2
- T238 F3
- T240 D6

\* OPTIONAL  
# Refer to Table

	SPDIF	4205	4206
HTS3100	EU	X	
HTS3105	ROW	X	
HTS3110	EU		X
HTS3450	ROW		X
	EU		
	ROW		





# Mono Board: Circuit Diagram MKI (Part 4)

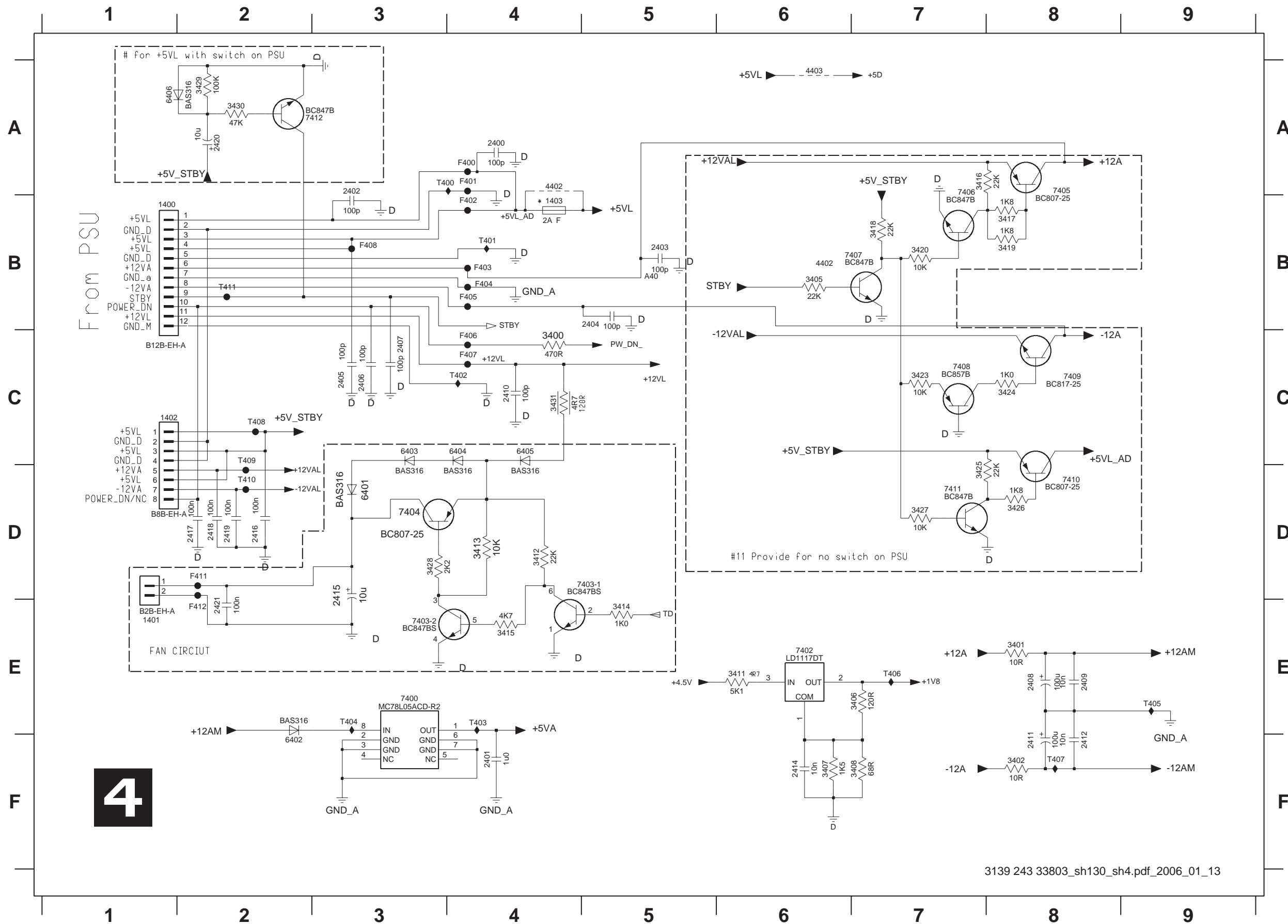

- 1400 B1
- 1401 E1
- 1402 C1
- 1403 B4
- 2400 A4
- 2401 F4
- 2402 A3
- 2403 B5
- 2404 B5
- 2405 C3
- 2406 C3
- 2407 C3
- 2408 E8
- 2409 E8
- 2410 C4
- 2411 F8
- 2412 F8
- 2414 F6
- 2415 D3
- 2416 D2
- 2417 D2
- 2418 D2
- 2419 D2
- 2420 A2
- 2421 E2
- 3400 C4
- 3401 E8
- 3402 F8
- 3405 B6
- 3406 E7
- 3407 F6
- 3408 F7
- 3411 E6
- 3412 D4
- 3413 D4
- 3414 E5
- 3415 E4
- 3416 A7
- 3417 B8
- 3418 B7
- 3419 B8
- 3420 B7
- 3423 C7
- 3424 C8
- 3425 D7
- 3426 D8
- 3427 D7
- 3428 D3
- 3429 A2
- 3430 A2
- 3431 C4
- 4402 A4
- 4403 A6
- 6401 D3
- 6402 F2
- 6403 C3
- 6404 C4
- 6405 C4
- 6406 A1
- 7400 E3
- 7402 E6
- 7403-1 D5
- 7403-2 E3
- 7404 D3
- 7405 A8
- 7406 A7
- 7407 B6
- 7408 C7
- 7409 C8
- 7410 D8
- 7411 D7
- 7412 A2
- F400 A4
- F401 A4
- F402 B4
- F403 B4
- F404 B4
- F405 B4
- F406 C4
- F407 C4
- F408 B3
- F411 D2
- F412 E2
- T400 A3
- T401 B4
- T402 C4
- T403 E3
- T404 E3
- T405 E9
- T406 E7
- T407 F8
- T408 C2
- T409 E2
- T410 D2
- T411 B2

# 4

Mono Board: Circuit Diagram MKI (Part 5)

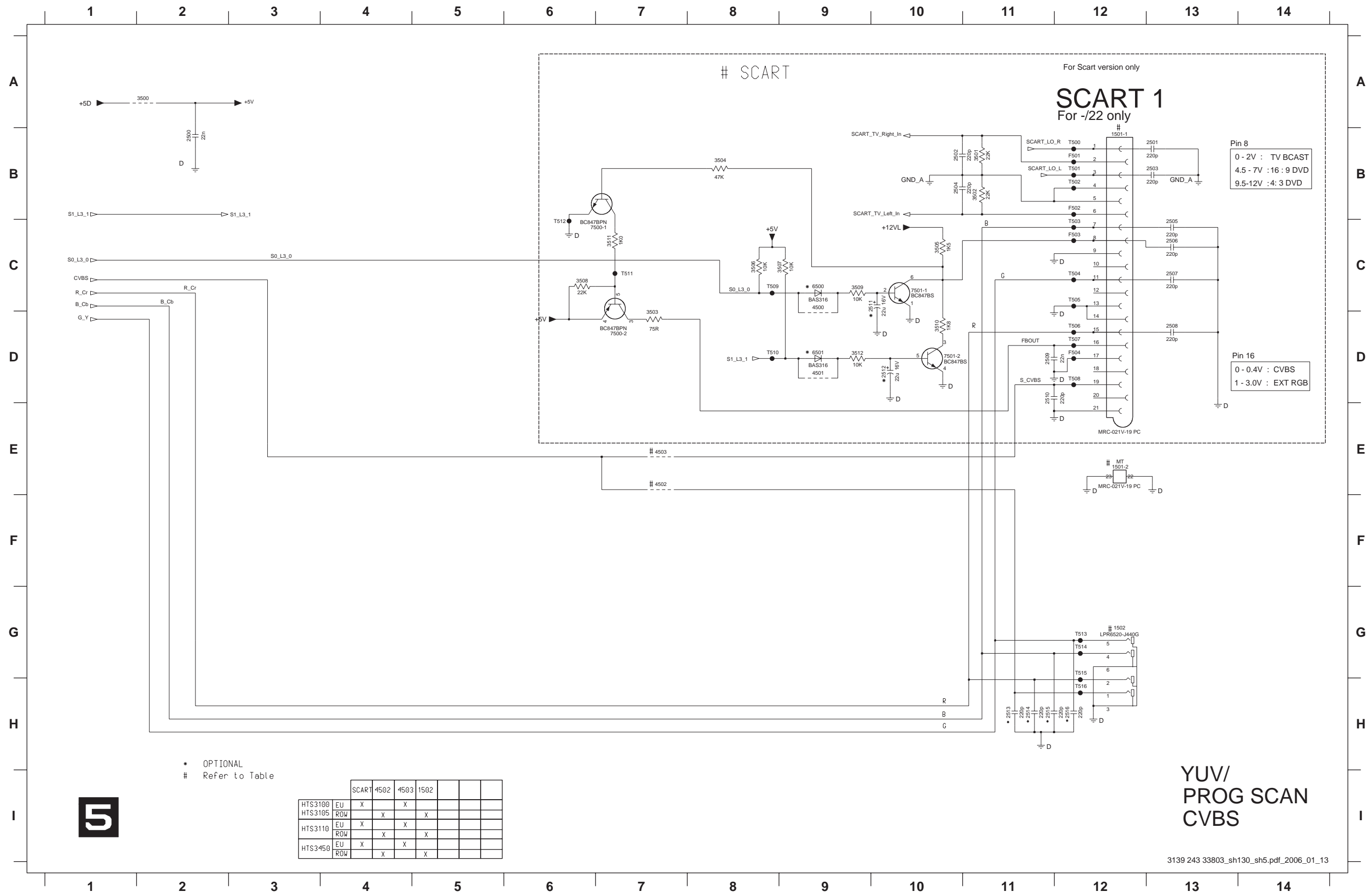

- 1501-1 B12
- 1501-2 E12
- 1502 G12
- 2500 B2
- 2501 B13
- 2502 B10
- 2503 B13
- 2504 B10
- 2505 C13
- 2506 C13
- 2507 C13
- 2508 D13
- 2509 D11
- 2510 D11
- 2511 C10
- 2512 D10
- 2513 H11
- 2514 H11
- 2515 H11
- 2516 H12
- 3500 A2
- 3501 B11
- 3502 B11
- 3503 C7
- 3504 B8
- 3505 C10
- 3506 C8
- 3507 C9
- 3508 C6
- 3509 C9
- 3510 D10
- 3511 C7
- 3512 D9
- 4500 C9
- 4501 D9
- 4502 E7
- 4503 E7
- 6500 C9
- 6501 D9
- 7500-1 C7
- 7500-2 D7
- 7501-1 C10
- 7501-2 D10
- F501 B12
- F502 B12
- F503 C12
- F504 D12
- T500 B12
- T501 B12
- T502 B12
- T503 C12
- T504 C12
- T505 C12
- T506 D12
- T507 D12
- T508 D12
- T509 C8
- T510 D8
- T511 C7
- T512 C6
- T513 G12
- T514 G12
- T515 G12
- T516 H12

• OPTIONAL  
# Refer to Table

		SCART	4502	4503	1502		
HTS3100	EU	X		X			
HTS3105	ROW		X		X		
HTS3110	EU	X		X			
	ROW		X		X		
HTS3450	EU	X		X			
	ROW		X		X		

**5**

YUV/  
PROG SCAN  
CVBS







# Mono Board: Circuit Diagram MKII (Part 1)

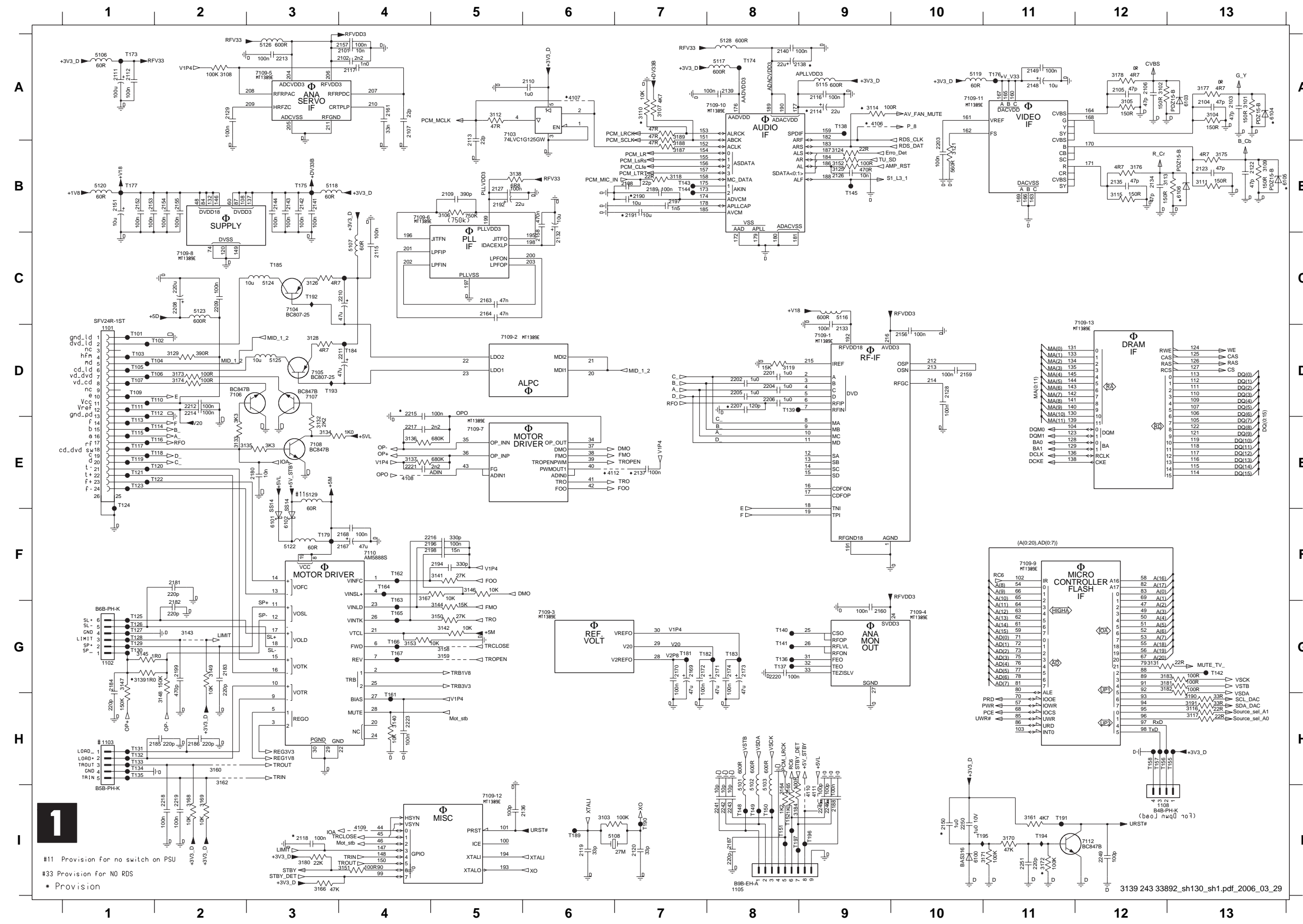

1101 D1	2249 H12	6106 B13
1102 G1	7103 A5	7103 A5
1103 H1	2251 H1	7104 C3
1105 I8	3101 A13	7105 D3
1108 I12	3102 A12	7106 D2
2101 A4	3103 I6	7107 D3
2102 A4	3104 A13	7108 E3
2103 A13	3105 A12	7109-1 D9
2104 A13	3106 B5	7109-10 A8
2105 A12	3107 A7	7109-11 A11
2106 A12	3108 A2	7109-12 I5
2107 A4	3109 B13	7109-13 C12
2108 B7	3110 A7	7109-2 D5
2109 B5	3111 B13	7109-3 G6
2110 A6	3112 A5	7109-4 G10
2111 A1	3113 B12	7109-5 A3
2112 A1	3114 A9	7109-6 B4
2113 A5	3115 B12	7109-7 E5
2114 A9	3116 H3	7109-8 C2
2115 C4	3117 H13	7109-9 F11
2116 A9	3118 B7	7110 F4
2117 A4	3119 D8	7112 I12
2118 I3	3121 B10	7101 D1
2119 I6	3124 B9	7102 D1
2120 I7	3125 B9	7103 D2
2122 B13	3126 C3	7104 D2
2123 B3	3128 D3	7105 D1
2126 B9	3129 D2	7106 D2
2131 B5	3131 G12	7107 D1
2132 D10	3132 E2	7108 D1
2139 A2	3133 E2	7110 D2
2140 A8	3134 E3	7111 D1
2141 B3	3135 E4	7112 D2
2142 B3	3136 E4	7113 E1
2143 B3	3137 E4	7114 E2
2144 B3	3138 B5	7115 E1
2148 A11	3139 G1	7116 E2
2149 A11	3140 H4	7117 E1
2150 H10	3149 G2	7126 G1
2151 B1	3150 G5	7127 G1
2152 B1	3151 I4	7128 G1
2153 B1	3152 B9	7129 G1
2154 B2	3153 G4	7130 G1
2155 B2	3158 G5	7131 H1
2156 D10	3159 G5	7132 H1
2157 A4	3160 H2	7133 H1
2158 C6	3161 H1	7134 H1
2159 D10	3162 H2	7135 H1
2160 G9	3164 I8	7136 G8
2161 A4	3165 I8	7137 G8
2163 C5	3166 I3	7138 A9
2164 C5	3167 F4	7139 D8
2167 F4	3168 I2	7140 G8
2168 F4	3169 I2	7141 G8
2169 G7	3170 H1	7142 G13
2170 G7	3171 H1	7143 B7
2171 G8	3172 H1	7144 B7
2172 G7	3173 D2	7145 B9
2173 G8	3174 D2	7148 I8
2174 G8	3175 B3	7149 I8
2180 G2	3176 B12	7150 I8
2181 F2	3177 A13	7151 I8
2182 G2	3178 A12	7152 I8
2183 G2	3180 I3	7155 H12
2184 G1	3181 G12	7156 H12
2185 H2	3182 G12	7157 H12
2186 H2	3183 G12	7158 H12
2187 I8	3184 I8	7161 G4
2188 I9	3187 B7	7162 F4
2189 B7	3188 B7	7163 G4
2190 B7	3189 A7	7164 F4
2191 B7	3190 H13	7165 G4
2192 B5	3191 H13	7166 G4
2194 F5	4106 A9	7167 G4
2196 F4	4107 A6	7173 A1
2197 B7	4108 E4	7174 A8
2198 F4	4109 I4	7175 B3
2199 G2	4110 B1	7176 A11
2201 D8	4111 B9	7177 B1
2202 D8	4112 E6	7179 F3
2203 B10	5101 H8	7181 G7
2204 D8	5102 H8	7182 G7
2205 D8	5103 H8	7183 G8
2206 D8	5106 A1	7184 D4
2207 D8	5107 C4	7185 C3
2208 C2	5108 I6	7189 I6
2209 C2	5115 A9	7190 I7
2210 C3	5116 C9	7191 H1
2211 D3	5117 A8	7192 C3
2212 D2	5118 B3	7193 D3
2213 A3	5119 A10	7194 H1
2214 D2	5120 B1	7195 H10
2215 D4	5122 F3	7196 I9
2216 F4	5123 C3	7197 F4
2217 E4	5124 C3	7198 I8
2218 I2	5125 D3	
2219 I2	5126 A3	
2220 G8	5128 A8	
2221 E4	5129 E3	
2223 H4	6100 H10	
2241 I8	6101 F3	
2242 I8	6102 F3	
2243 I8	6103 A13	
2245 I9	6104 A13	
2246 I9	6105 B13	

1 Provision for no switch on PSU  
 #33 Provision for NO RDS  
 \* Provision

# Mono Board: Circuit Diagram MKII (Part 2)

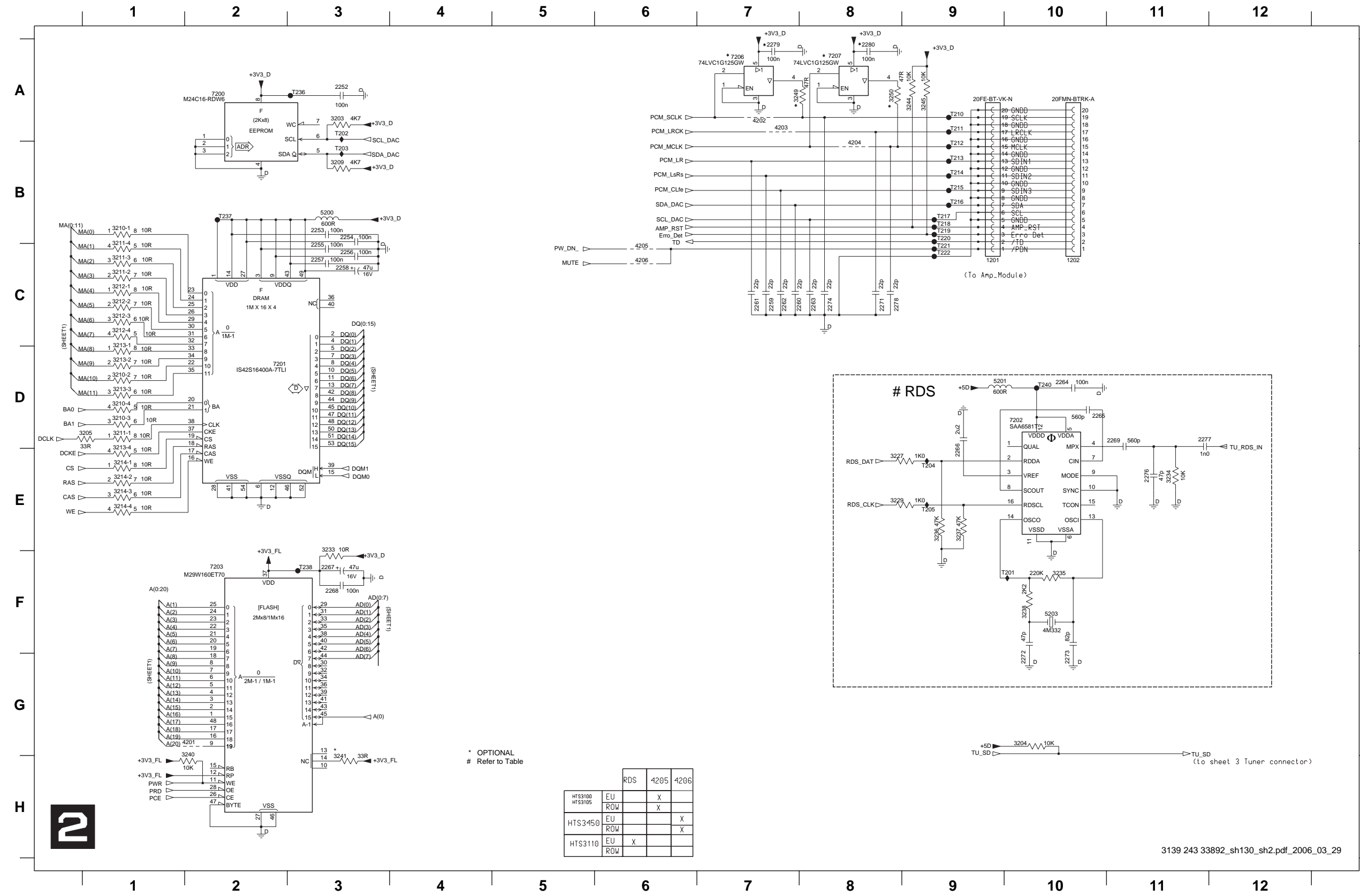

- 1201 C9
- 1202 C10
- 1252 A3
- 1253 B3
- 1254 B3
- 1255 B3
- 1256 C3
- 1257 C3
- 1258 C3
- 1259 C7
- 1260 C7
- 1261 C7
- 1262 C7
- 1263 C8
- 1264 D10
- 1265 D10
- 1266 E9
- 1267 F3
- 1268 F3
- 1269 D11
- 1271 C8
- 1272 G10
- 1273 G10
- 1274 C8
- 1276 E11
- 1277 D11
- 1278 C8
- 1279 A7
- 1280 A8
- 1283 A3
- 1284 G10
- 1285 D1
- 1289 B3
- 1290-1 B1
- 1290-2 D1
- 1290-3 D1
- 1290-4 D1
- 1291-1 D1
- 1291-2 C1
- 1291-3 C1
- 1291-4 C1
- 1292-1 C1
- 1292-2 C1
- 1292-3 C1
- 1292-4 C1
- 1293-1 D1
- 1293-2 D1
- 1293-3 D1
- 1293-4 E1
- 1294-1 E1
- 1294-2 E1
- 1294-3 E1
- 1294-4 E1
- 1297 E8
- 1299 E8
- 1303 F3
- 1304 E11
- 1305 F10
- 1306 E9
- 1307 E9
- 1308 F10
- 1340 H2
- 1341 H3
- 1344 A9
- 1345 A9
- 1349 A7
- 1350 A8
- 1401 G2
- 1402 A7
- 1403 A7
- 1404 A8
- 1405 C6
- 1406 C6
- 1500 B3
- 1501 D9
- 1503 F10
- 1700 A2
- 1701 D2
- 1702 D10
- 1703 F2
- 1706 A7
- 1707 A8
- 1708 F10
- 1709 F10
- 1710 A9
- 1711 A9
- 1712 B9
- 1713 B9
- 1714 B9
- 1715 B9
- 1716 B9
- 1717 B9
- 1718 B9
- 1719 B9
- 1720 B9

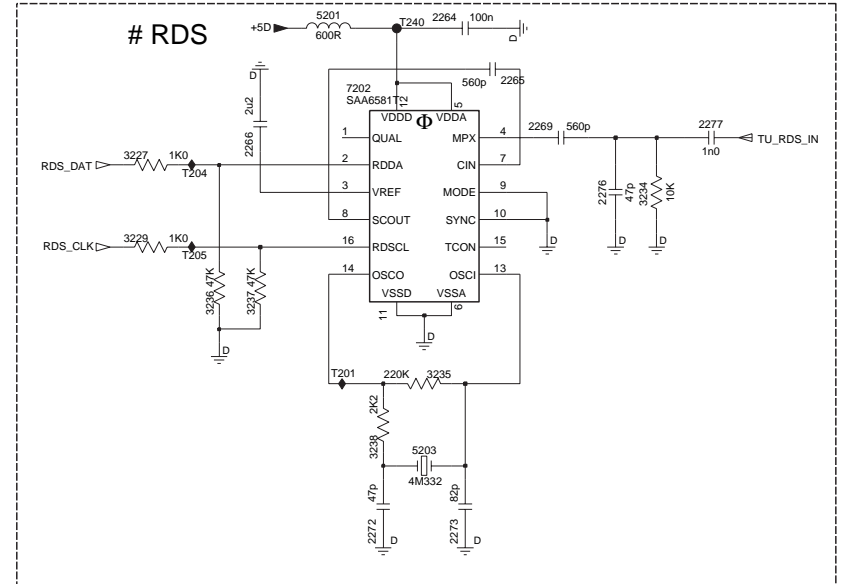

\* OPTIONAL  
# Refer to Table

	RDS	4205	4206
HTS3100	EU	X	
HTS3105	ROW		
HTS3450	EU		X
	ROW		X
HTS3110	EU	X	
	ROW		



# Mono Board: Circuit Diagram MKII (Part 3)

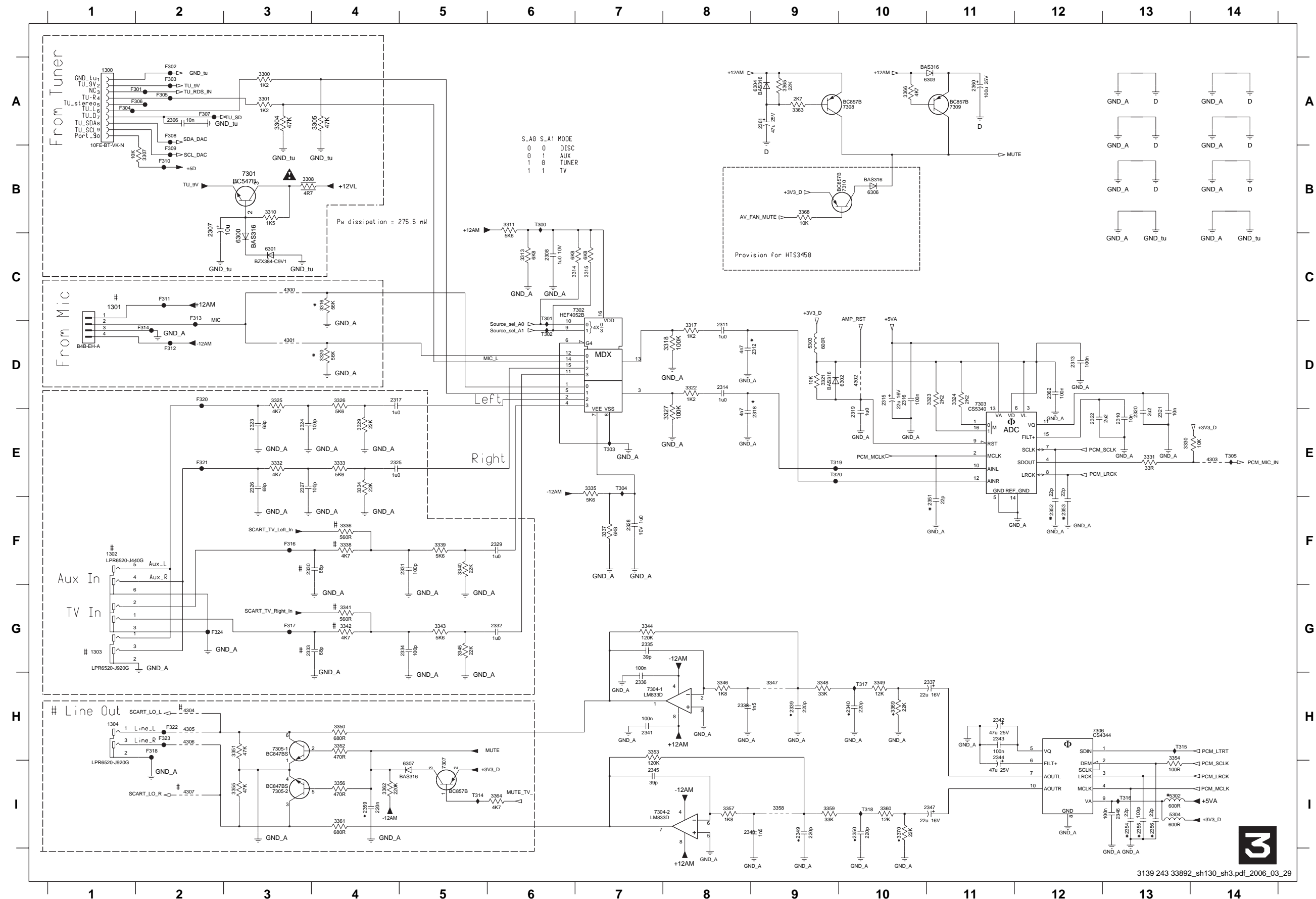

- 1300 A1
- 1301 C1
- 1302 F1
- 1303 G1
- 1304 H1
- 2306 A2
- 2307 B2
- 2308 C6
- 2310 E13
- 2311 D8
- 2312 D9
- 2313 D12
- 2314 D8
- 2315 D10
- 2316 D10
- 2317 D4
- 2318 E9
- 2319 E10
- 2320 E13
- 2321 E13
- 2322 E12
- 2323 E3
- 2324 E3
- 2325 E4
- 2326 E3
- 2327 E3
- 2328 F7
- 2329 F6
- 2330 F3
- 2331 F5
- 2332 G6
- 2333 G3
- 2334 G5
- 2335 G7
- 2336 H7
- 2337 H11
- 2338 H8
- 2339 H9
- 2340 H10
- 2341 H7
- 2342 H11
- 2343 H11
- 2344 H11
- 2345 I7
- 2346 I13
- 2347 I11
- 2348 I8
- 2349 I9
- 2350 I10
- 2351 F11
- 2352 F12
- 2353 F12
- 2354 I13
- 2355 I13
- 2356 I13
- 2357 I13
- 2358 I13
- 2359 I4
- 2360 A11
- 2361 A9
- 2362 D12
- 2363 A3
- 2364 A3
- 2365 A3
- 2366 B2
- 2367 B2
- 2368 B3
- 2369 B3
- 2370 B3
- 2371 B3
- 2372 B3
- 2373 B3
- 2374 B3
- 2375 B3
- 2376 B3
- 2377 B3
- 2378 B3
- 2379 B3
- 2380 B3
- 2381 B3
- 2382 B3
- 2383 B3
- 2384 B3
- 2385 B3
- 2386 B3
- 2387 B3
- 2388 B3
- 2389 B3
- 2390 B3
- 2391 B3
- 2392 B3
- 2393 B3
- 2394 B3
- 2395 B3
- 2396 B3
- 2397 B3
- 2398 B3
- 2399 B3
- 2400 B3
- 2401 B3
- 2402 B3
- 2403 B3
- 2404 B3
- 2405 B3
- 2406 B3
- 2407 B3
- 2408 B3
- 2409 B3
- 2410 B3
- 2411 B3
- 2412 B3
- 2413 B3
- 2414 B3
- 2415 B3
- 2416 B3
- 2417 B3
- 2418 B3
- 2419 B3
- 2420 B3
- 2421 B3
- 2422 B3
- 2423 B3
- 2424 B3
- 2425 B3
- 2426 B3
- 2427 B3
- 2428 B3
- 2429 B3
- 2430 B3
- 2431 B3
- 2432 B3
- 2433 B3
- 2434 B3
- 2435 B3
- 2436 B3
- 2437 B3
- 2438 B3
- 2439 B3
- 2440 B3
- 2441 B3
- 2442 B3
- 2443 B3
- 2444 B3
- 2445 B3
- 2446 B3
- 2447 B3
- 2448 B3
- 2449 B3
- 2450 B3
- 2451 B3
- 2452 B3
- 2453 B3
- 2454 B3
- 2455 B3
- 2456 B3
- 2457 B3
- 2458 B3
- 2459 B3
- 2460 B3
- 2461 B3
- 2462 B3
- 2463 B3
- 2464 B3
- 2465 B3
- 2466 B3
- 2467 B3
- 2468 B3
- 2469 B3
- 2470 B3
- 2471 B3
- 2472 B3
- 2473 B3
- 2474 B3
- 2475 B3
- 2476 B3
- 2477 B3
- 2478 B3
- 2479 B3
- 2480 B3
- 2481 B3
- 2482 B3
- 2483 B3
- 2484 B3
- 2485 B3
- 2486 B3
- 2487 B3
- 2488 B3
- 2489 B3
- 2490 B3
- 2491 B3
- 2492 B3
- 2493 B3
- 2494 B3
- 2495 B3
- 2496 B3
- 2497 B3
- 2498 B3
- 2499 B3
- 2500 B3
- 2501 B3
- 2502 B3
- 2503 B3
- 2504 B3
- 2505 B3
- 2506 B3
- 2507 B3
- 2508 B3
- 2509 B3
- 2510 B3
- 2511 B3
- 2512 B3
- 2513 B3
- 2514 B3
- 2515 B3
- 2516 B3
- 2517 B3
- 2518 B3
- 2519 B3
- 2520 B3
- 2521 B3
- 2522 B3
- 2523 B3
- 2524 B3
- 2525 B3
- 2526 B3
- 2527 B3
- 2528 B3
- 2529 B3
- 2530 B3
- 2531 B3
- 2532 B3
- 2533 B3
- 2534 B3
- 2535 B3
- 2536 B3
- 2537 B3
- 2538 B3
- 2539 B3
- 2540 B3
- 2541 B3
- 2542 B3
- 2543 B3
- 2544 B3
- 2545 B3
- 2546 B3
- 2547 B3
- 2548 B3
- 2549 B3
- 2550 B3
- 2551 B3
- 2552 B3
- 2553 B3
- 2554 B3
- 2555 B3
- 2556 B3
- 2557 B3
- 2558 B3
- 2559 B3
- 2560 B3
- 2561 B3
- 2562 B3
- 2563 B3
- 2564 B3
- 2565 B3
- 2566 B3
- 2567 B3
- 2568 B3
- 2569 B3
- 2570 B3
- 2571 B3
- 2572 B3
- 2573 B3
- 2574 B3
- 2575 B3
- 2576 B3
- 2577 B3
- 2578 B3
- 2579 B3
- 2580 B3
- 2581 B3
- 2582 B3
- 2583 B3
- 2584 B3
- 2585 B3
- 2586 B3
- 2587 B3
- 2588 B3
- 2589 B3
- 2590 B3
- 2591 B3
- 2592 B3
- 2593 B3
- 2594 B3
- 2595 B3
- 2596 B3
- 2597 B3
- 2598 B3
- 2599 B3
- 2600 B3
- 2601 B3
- 2602 B3
- 2603 B3
- 2604 B3
- 2605 B3
- 2606 B3
- 2607 B3
- 2608 B3
- 2609 B3
- 2610 B3
- 2611 B3
- 2612 B3
- 2613 B3
- 2614 B3
- 2615 B3
- 2616 B3
- 2617 B3
- 2618 B3
- 2619 B3
- 2620 B3
- 2621 B3
- 2622 B3
- 2623 B3
- 2624 B3
- 2625 B3
- 2626 B3
- 2627 B3
- 2628 B3
- 2629 B3
- 2630 B3
- 2631 B3
- 2632 B3
- 2633 B3
- 2634 B3
- 2635 B3
- 2636 B3
- 2637 B3
- 2638 B3
- 2639 B3
- 2640 B3
- 2641 B3
- 2642 B3
- 2643 B3
- 2644 B3
- 2645 B3
- 2646 B3
- 2647 B3
- 2648 B3
- 2649 B3
- 2650 B3
- 2651 B3
- 2652 B3
- 2653 B3
- 2654 B3
- 2655 B3
- 2656 B3
- 2657 B3
- 2658 B3
- 2659 B3
- 2660 B3
- 2661 B3
- 2662 B3
- 2663 B3
- 2664 B3
- 2665 B3
- 2666 B3
- 2667 B3
- 2668 B3
- 2669 B3
- 2670 B3
- 2671 B3
- 2672 B3
- 2673 B3
- 2674 B3
- 2675 B3
- 2676 B3
- 2677 B3
- 2678 B3
- 2679 B3
- 2680 B3
- 2681 B3
- 2682 B3
- 2683 B3
- 2684 B3
- 2685 B3
- 2686 B3
- 2687 B3
- 2688 B3
- 2689 B3
- 2690 B3
- 2691 B3
- 2692 B3
- 2693 B3
- 2694 B3
- 2695 B3
- 2696 B3
- 2697 B3
- 2698 B3
- 2699 B3
- 2700 B3
- 2701 B3
- 2702 B3
- 2703 B3
- 2704 B3
- 2705 B3
- 2706 B3
- 2707 B3
- 2708 B3
- 2709 B3
- 2710 B3
- 2711 B3
- 2712 B3
- 2713 B3
- 2714 B3
- 2715 B3
- 2716 B3
- 2717 B3
- 2718 B3
- 2719 B3
- 2720 B3
- 2721 B3
- 2722 B3
- 2723 B3
- 2724 B3
- 2725 B3
- 2726 B3
- 2727 B3
- 2728 B3
- 2729 B3
- 2730 B3
- 2731 B3
- 2732 B3
- 2733 B3
- 2734 B3
- 2735 B3
- 2736 B3
- 2737 B3
- 2738 B3
- 2739 B3
- 2740 B3
- 2741 B3
- 2742 B3
- 2743 B3
- 2744 B3
- 2745 B3
- 2746 B3
- 2747 B3
- 2748 B3
- 2749 B3
- 2750 B3
- 2751 B3
- 2752 B3
- 2753 B3
- 2754 B3
- 2755 B3
- 2756 B3
- 2757 B3
- 2758 B3
- 2759 B3
- 2760 B3
- 2761 B3
- 2762 B3
- 2763 B3
- 2764 B3
- 2765 B3
- 2766 B3
- 2767 B3
- 2768 B3
- 2769 B3
- 2770 B3
- 2771 B3
- 2772 B3
- 2773 B3
- 2774 B3
- 2775 B3
- 2776 B3
- 2777 B3
- 2778 B3
- 2779 B3
- 2780 B3
- 2781 B3
- 2782 B3
- 2783 B3
- 2784 B3
- 2785 B3
- 2786 B3
- 2787 B3
- 2788 B3
- 2789 B3
- 2790 B3
- 2791 B3
- 2792 B3
- 2793 B3
- 2794 B3
- 2795 B3
- 2796 B3
- 2797 B3
- 2798 B3
- 2799 B3
- 2800 B3
- 2801 B3
- 2802 B3
- 2803 B3
- 2804 B3
- 2805 B3
- 2806 B3
- 2807 B3
- 2808 B3
- 2809 B3
- 2810 B3
- 2811 B3
- 2812 B3
- 2813 B3
- 2814 B3
- 2815 B3
- 2816 B3
- 2817 B3
- 2818 B3
- 2819 B3
- 2820 B3
- 2821 B3
- 2822 B3
- 2823 B3
- 2824 B3
- 2825 B3
- 2826 B3
- 2827 B3
- 2828 B3
- 2829 B3
- 2830 B3
- 2831 B3
- 2832 B3
- 2833 B3
- 2834 B3
- 2835 B3
- 2836 B3
- 2837 B3
- 2838 B3
- 2839 B3
- 2840 B3
- 2841 B3
- 2842 B3
- 2843 B3
- 2844 B3
- 2845 B3
- 2846 B3
- 2847 B3
- 2848 B3
- 2849 B3
- 2850 B3
- 2851 B3
- 2852 B3
- 2853 B3
- 2854 B3
- 2855 B3
- 2856 B3
- 2857 B3
- 2858 B3
- 2859 B3
- 2860 B3
- 2861 B3
- 2862 B3
- 2863 B3
- 2864 B3
- 2865 B3
- 2866 B3
- 2867 B3
- 2868 B3
- 2869 B3
- 2870 B3
- 2871 B3
- 2872 B3
- 2873 B3
- 2874 B3
- 2875 B3
- 2876 B3
- 2877 B3
- 2878 B3
- 2879 B3
- 2880 B3
- 2881 B3
- 2882 B3
- 2883 B3
- 2884 B3
- 2885 B3
- 2886 B3
- 2887 B3
- 2888 B3
- 2889 B3
- 2890 B3
- 2891 B3
- 2892 B3
- 2893 B3
- 2894 B3
- 2895 B3
- 2896 B3
- 2897 B3
- 2898 B3
- 2899 B3
- 2900 B3
- 2901 B3
- 2902 B3
- 2903 B3
- 2904 B3
- 2905 B3
- 2906 B3
- 2907 B3
- 2908 B3
- 2909 B3
- 2910 B3
- 2911 B3
- 2912 B3
- 2913 B3
- 2914 B3
- 2915 B3
- 2916 B3
- 2917 B3
- 2918 B3
- 2919 B3
- 2920 B3
- 2921 B3
- 2922 B3
- 2923 B3
- 292

# Mono Board: Circuit Diagram MKII (Part 4)

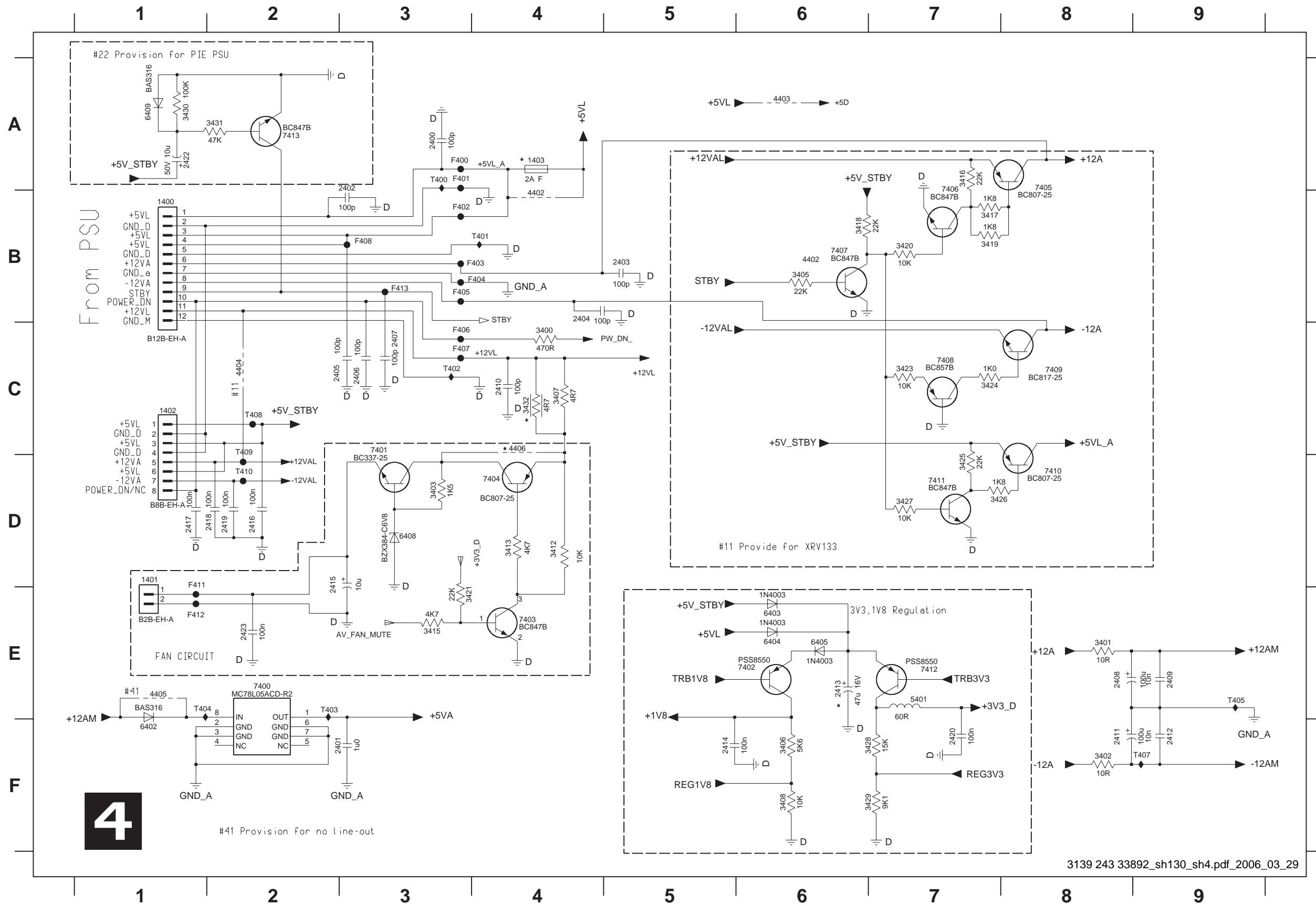

- 1400 B1
- 1401 D1
- 1402 C1
- 1403 A4
- 2400 A3
- 2401 F3
- 2402 B3
- 2403 B5
- 2404 B4
- 2405 C2
- 2406 C3
- 2407 C3
- 2408 E8
- 2409 E9
- 2410 C4
- 2411 F8
- 2412 F9
- 2413 E6
- 2414 F5
- 2415 D2
- 2416 D2
- 2417 D1
- 2418 D2
- 2419 D2
- 2420 F7
- 2422 A1
- 2423 E2
- 3400 C4
- 3401 E8
- 3402 F8
- 3403 D3
- 3405 B6
- 3406 F6
- 3407 C4
- 3408 F6
- 3412 D4
- 3413 D4
- 3415 E3
- 3416 A7
- 3417 B7
- 3418 B6
- 3419 B7
- 3420 B7
- 3421 E3
- 3423 C7
- 3424 C7
- 3425 D7
- 3426 D7
- 3427 D7
- 3428 F7
- 3429 F7
- 3430 A1
- 3431 A2
- 3432 C4
- 4402 B4
- 4403 A6
- 4404 C2
- 4405 E1
- 4406 C4
- 5401 E7
- 6402 F1
- 6403 E6
- 6404 E6
- 6405 E6
- 6408 D3
- 6409 A1
- 7400 E2
- 7401 C3
- 7402 E6
- 7403 E4
- 7404 D4
- 7405 A8
- 7406 B7
- 7407 B6
- 7408 C7
- 7409 C8
- 7410 D8
- 7411 D7
- 7412 E7
- 7413 A2
- F400 A3
- F401 A3
- F402 B3
- F403 B4
- F404 B4
- F405 B3
- F406 C3
- F407 C3
- F408 B3
- F411 E1
- F412 E1
- F413 B3
- T400 A3
- T401 B4
- T402 C3
- T403 E2
- T404 E1
- T405 E9
- T407 F9
- T408 C2
- T409 D2
- T410 D2











# PSU Circuit Diagram (For information only) PSU: Europe

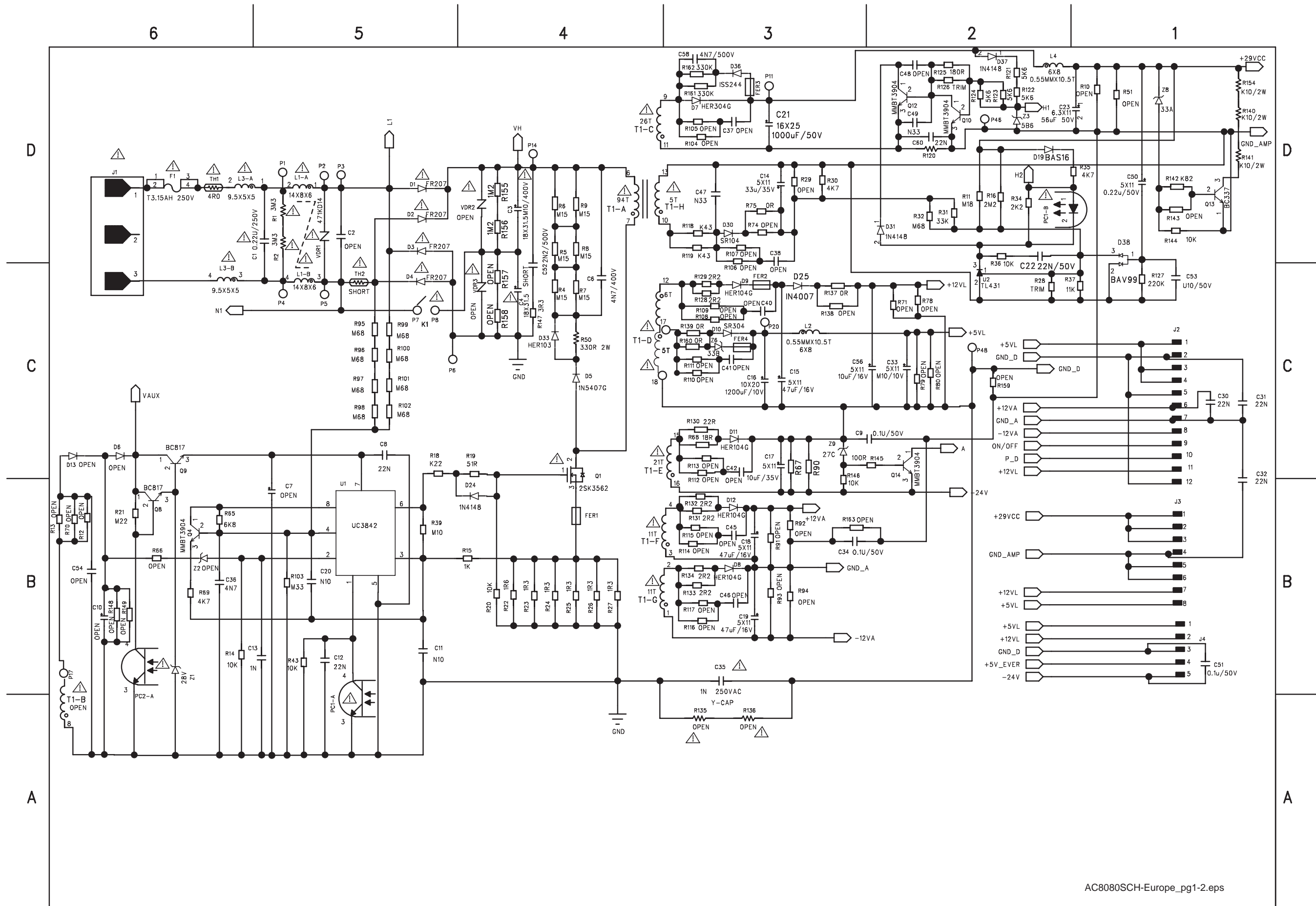

PSU Circuit Diagram (For information only) PSU: Europe

6

5

4

3

2

1

REVISION RECORD			
LTR	ECO NO:	APPROVED:	DATE:

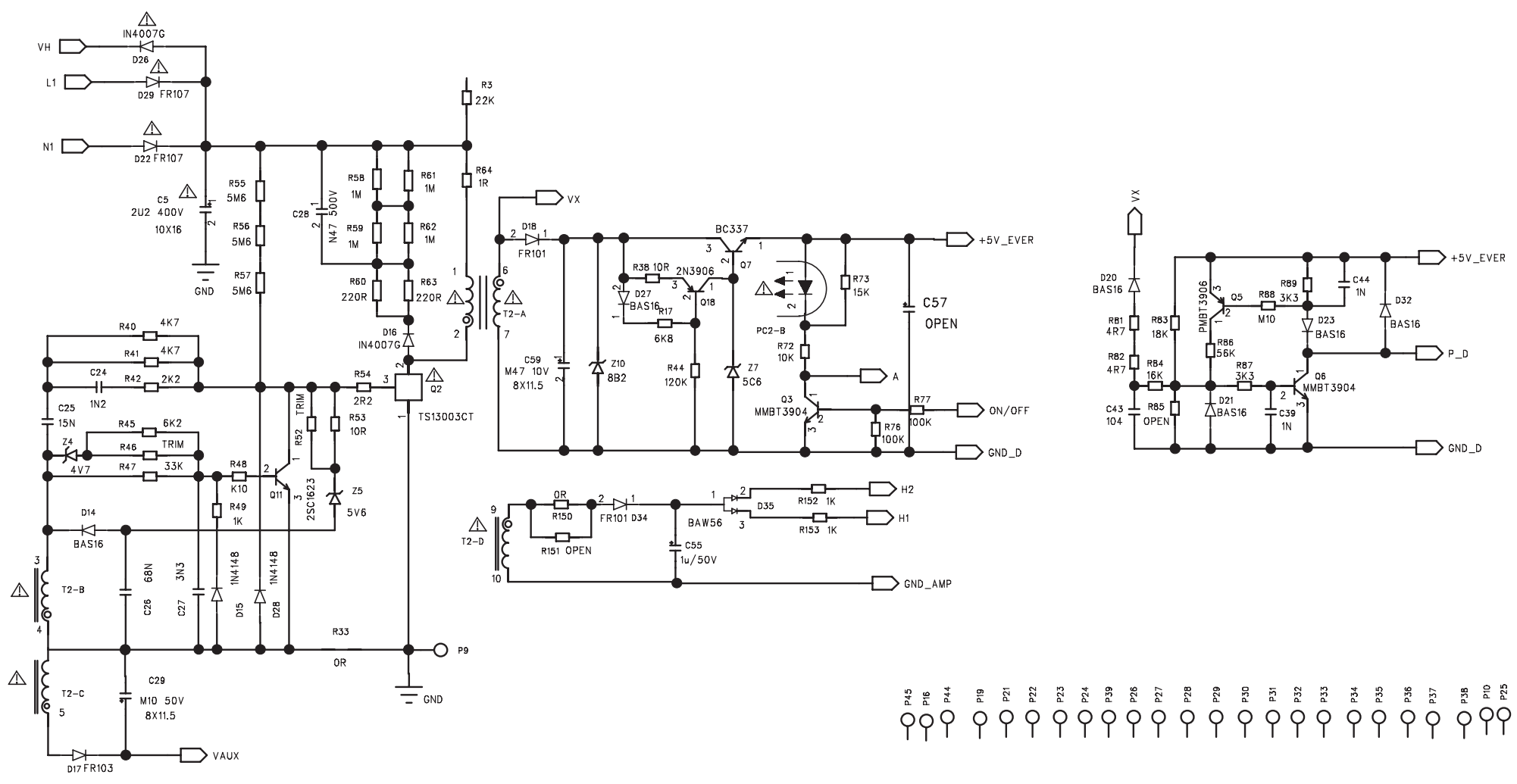

- P45
- P16
- P44
- P19
- P21
- P22
- P23
- P24
- P39
- P26
- P27
- P28
- P29
- P30
- P31
- P32
- P33
- P34
- P35
- P36
- P37
- P38
- P10
- P25
- P40
- P41
- P12
- P13
- P49
- P51
- P42
- P43

# PSU Circuit Diagram (For information only) PSU: AP

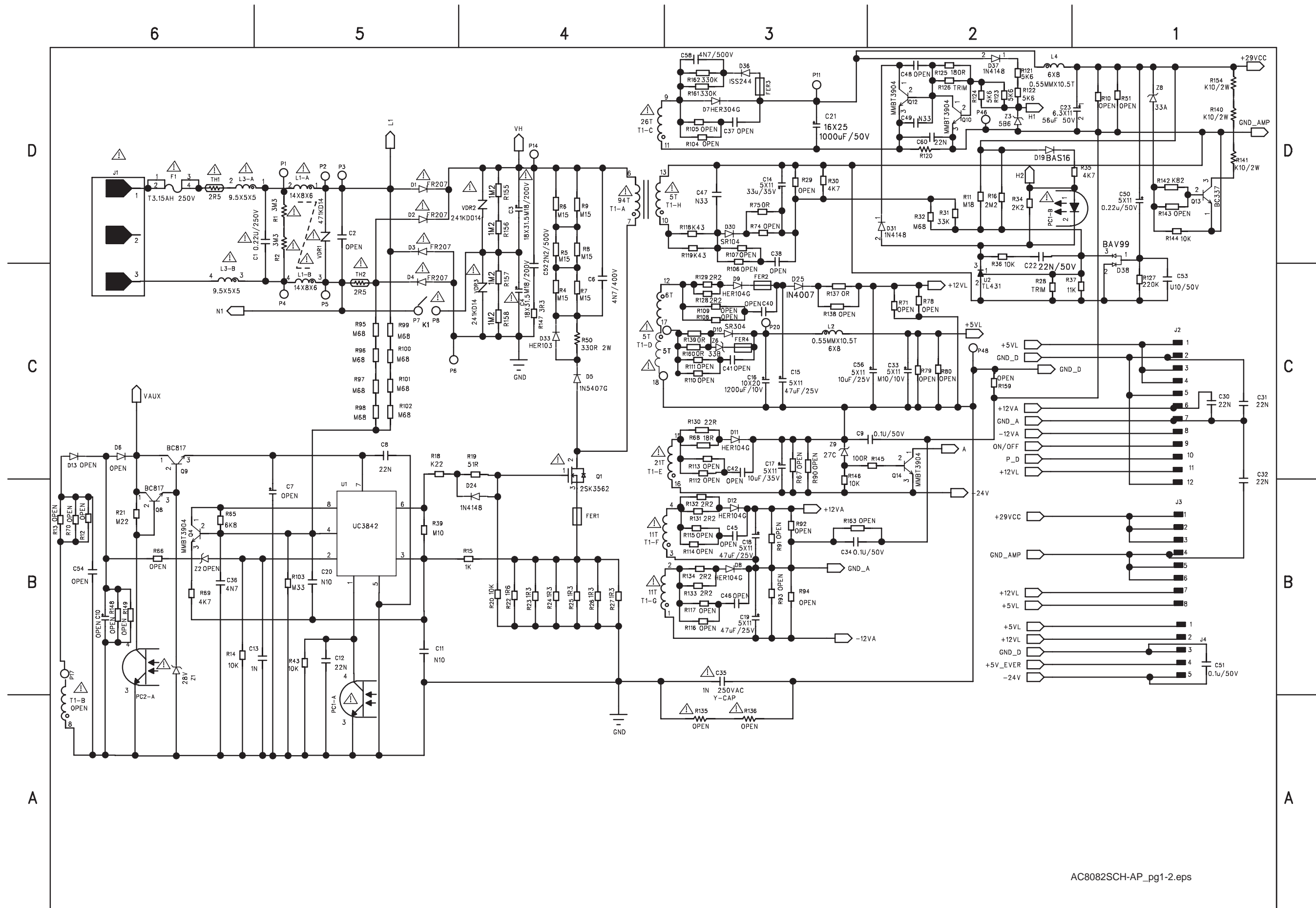

PSU Circuit Diagram (For information only) PSU: AP

REVISION RECORD			
LTR	ECO NO:	APPROVED:	DATE:

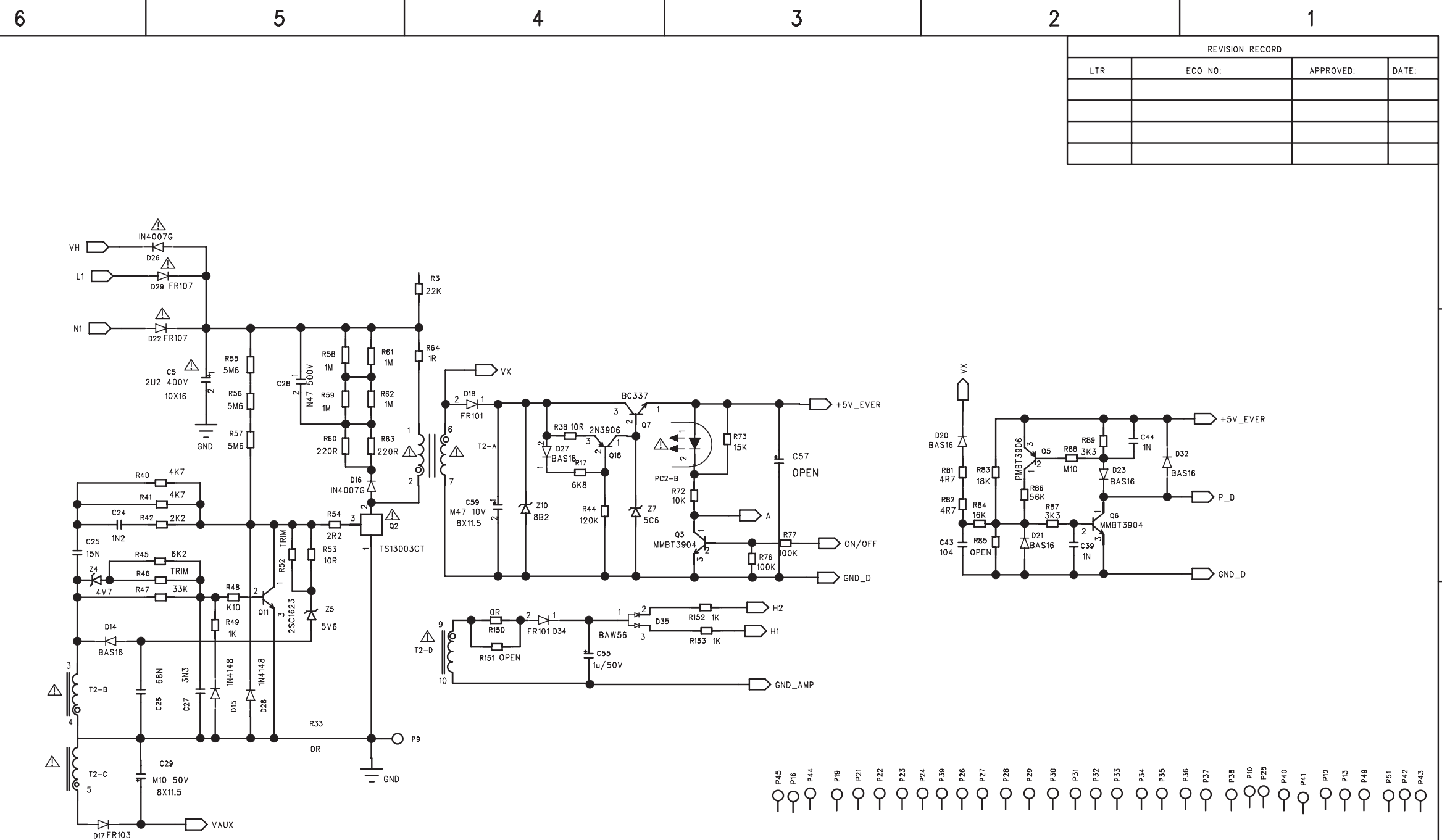

- P45
- P16
- P44
- P19
- P21
- P22
- P23
- P24
- P39
- P26
- P27
- P28
- P29
- P30
- P31
- P32
- P33
- P34
- P35
- P36
- P37
- P38
- P10
- P25
- P40
- P41
- P12
- P13
- P49
- P51
- P42
- P43

For information only (Amp Board)

### TAS5086-5142V6REF

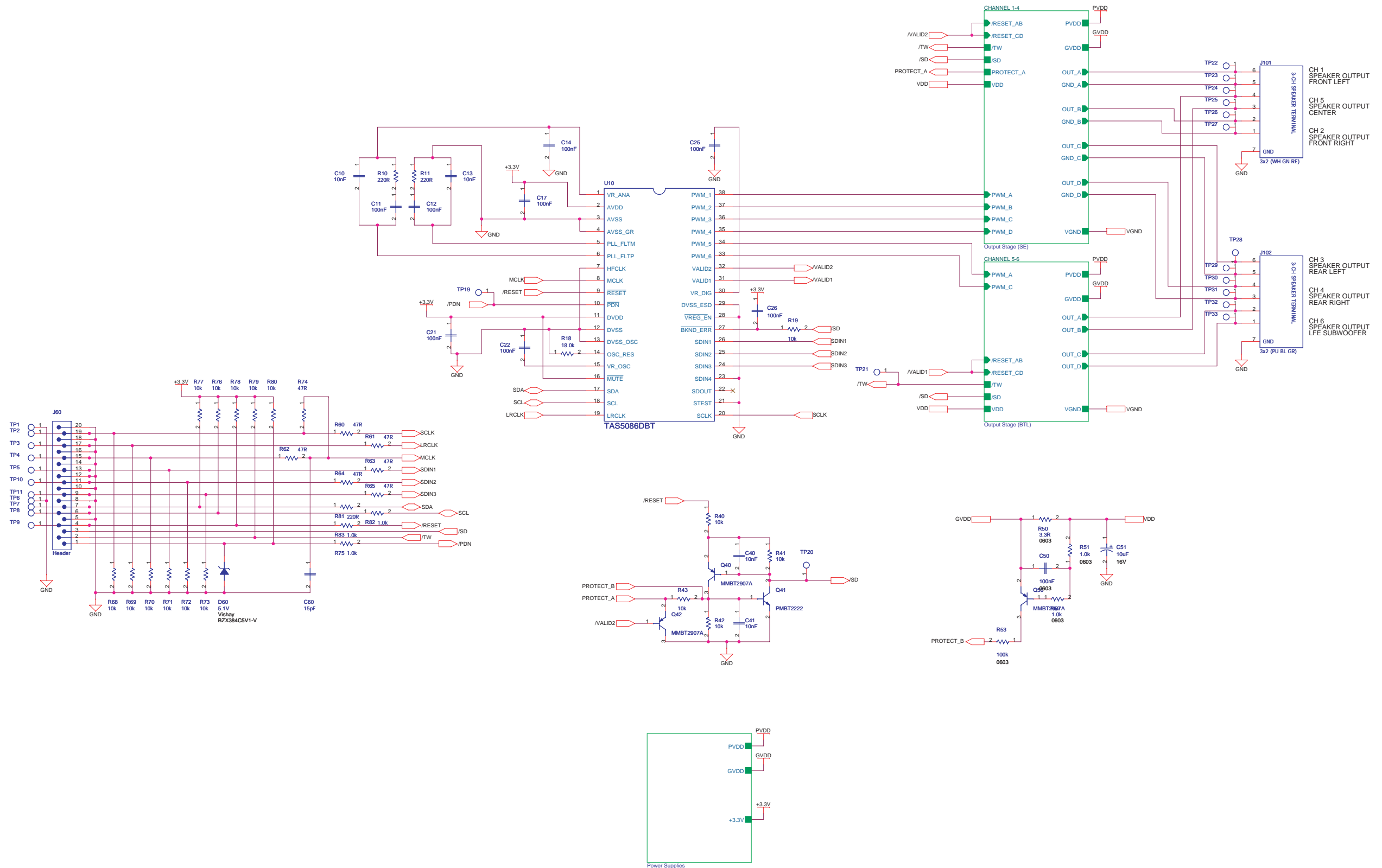



For information only (Amp Board)

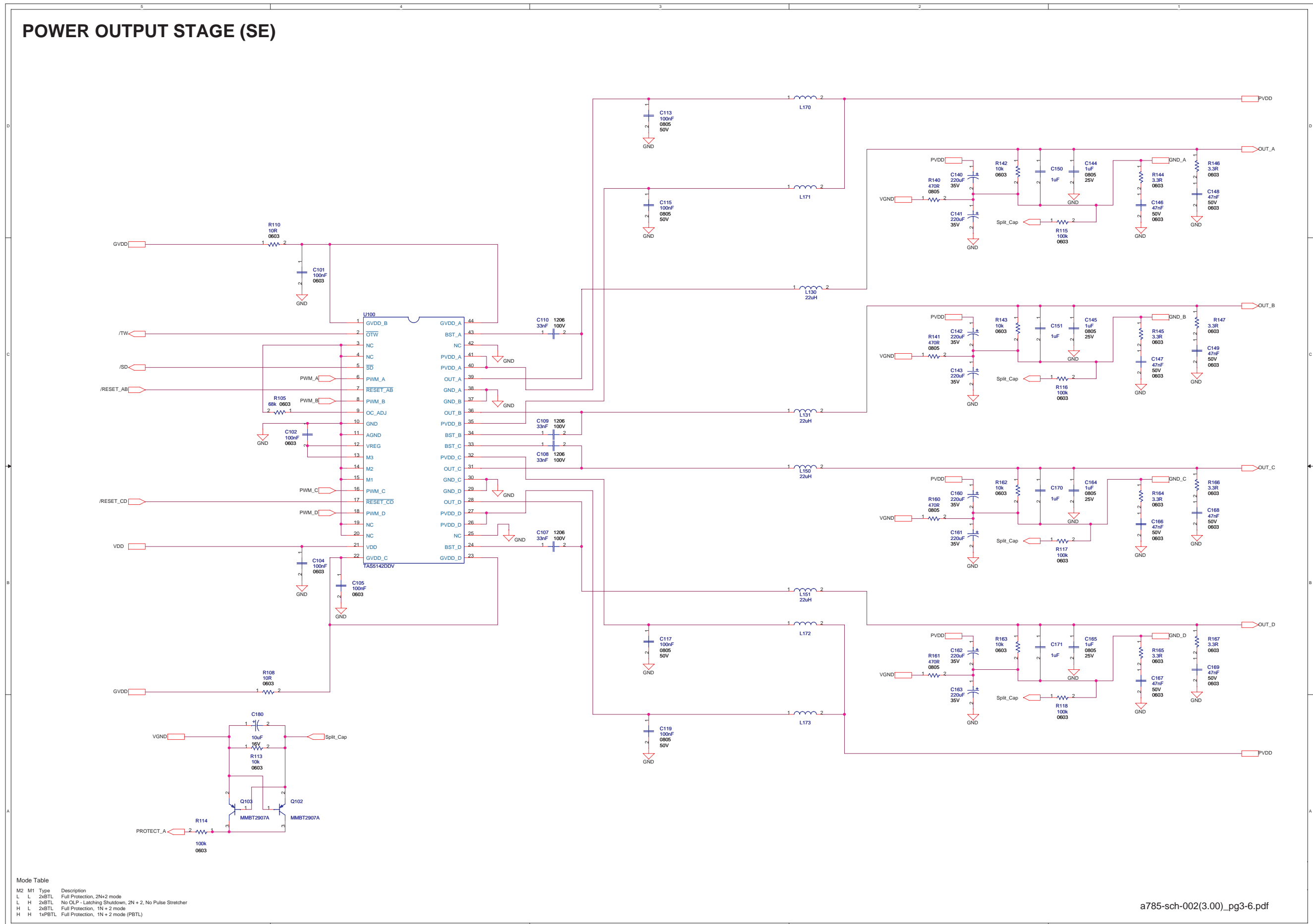

For information only (Amp Board)

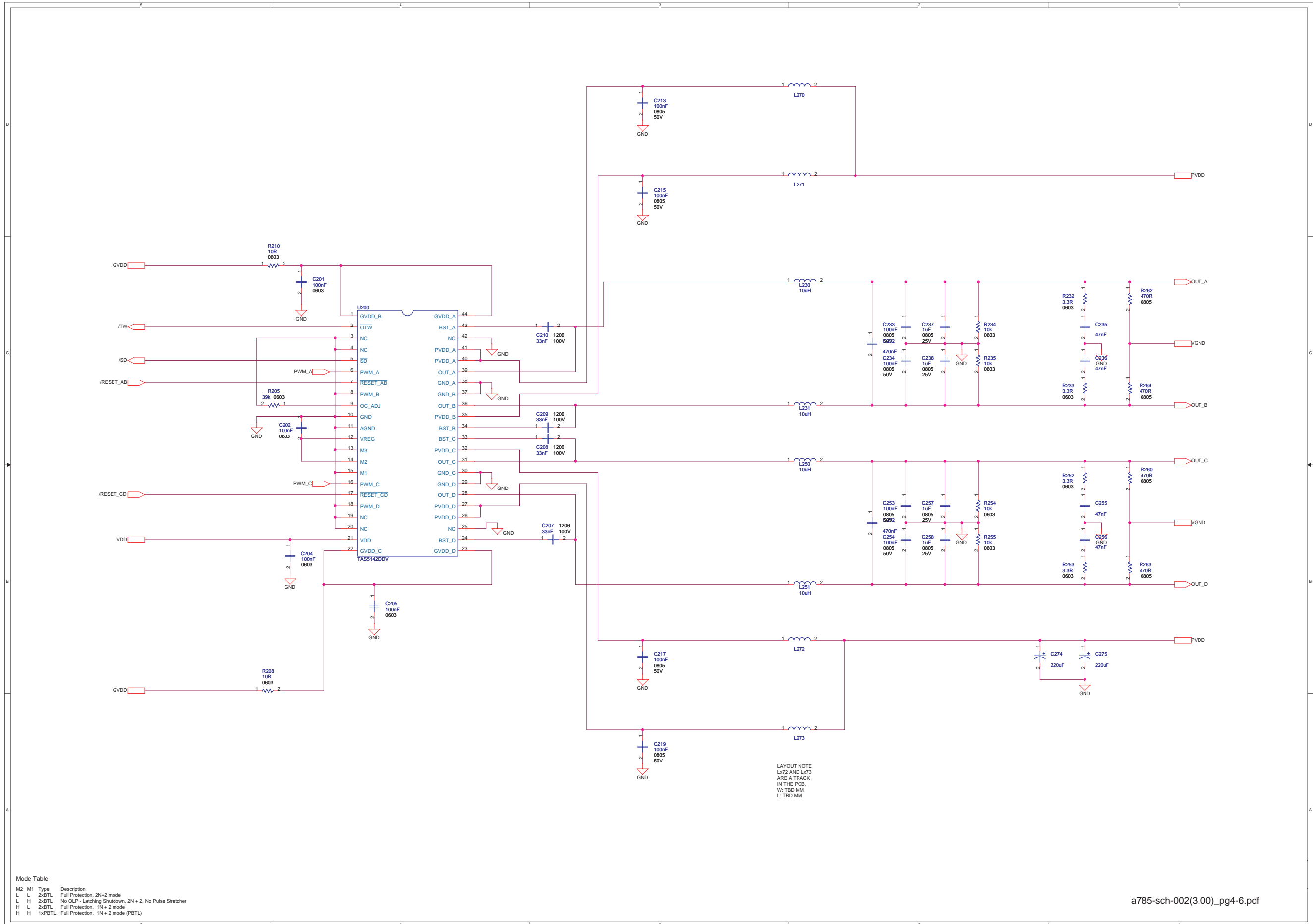

For information only (Amp Board)

### POWER SUPPLIES

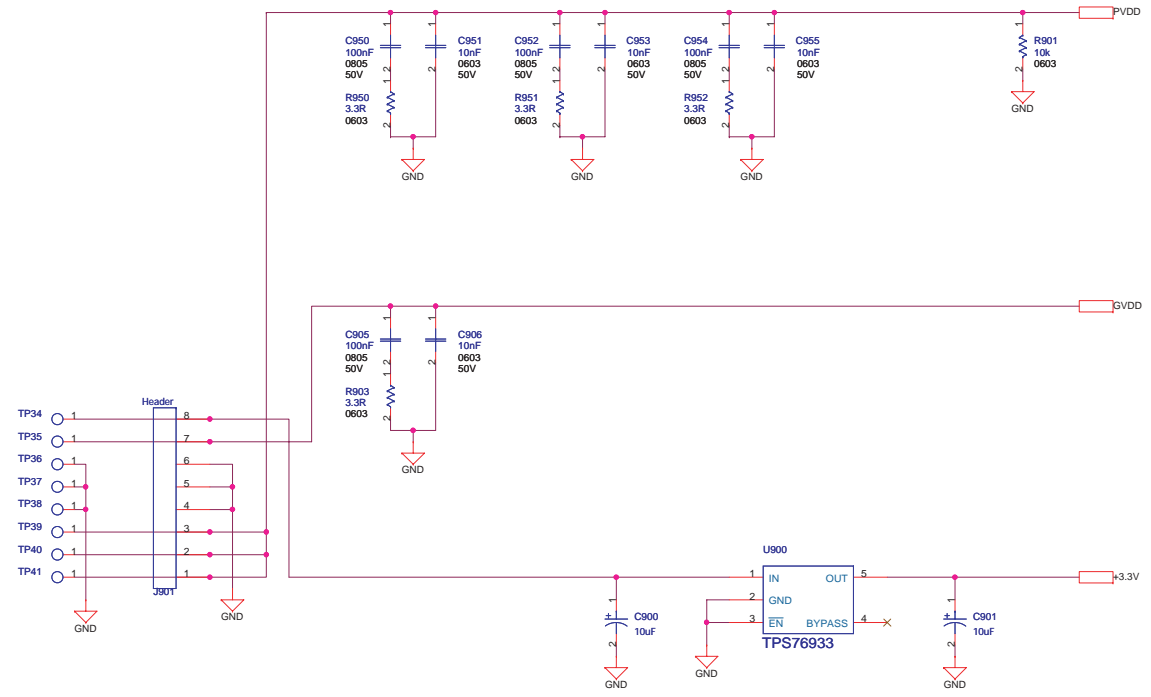

### Amp Board Layout : Topview

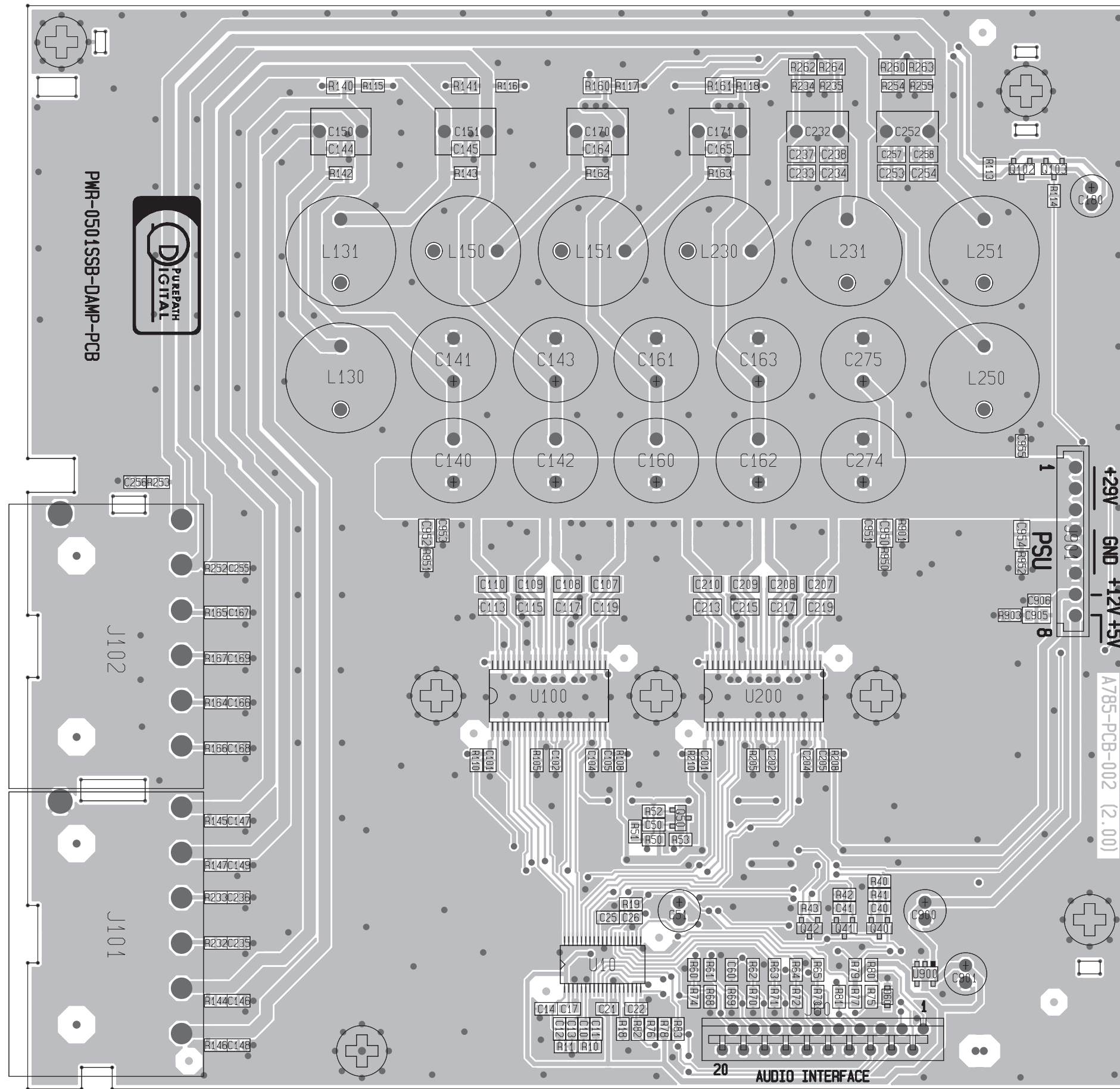

### Amp Board Layout : Bottomview

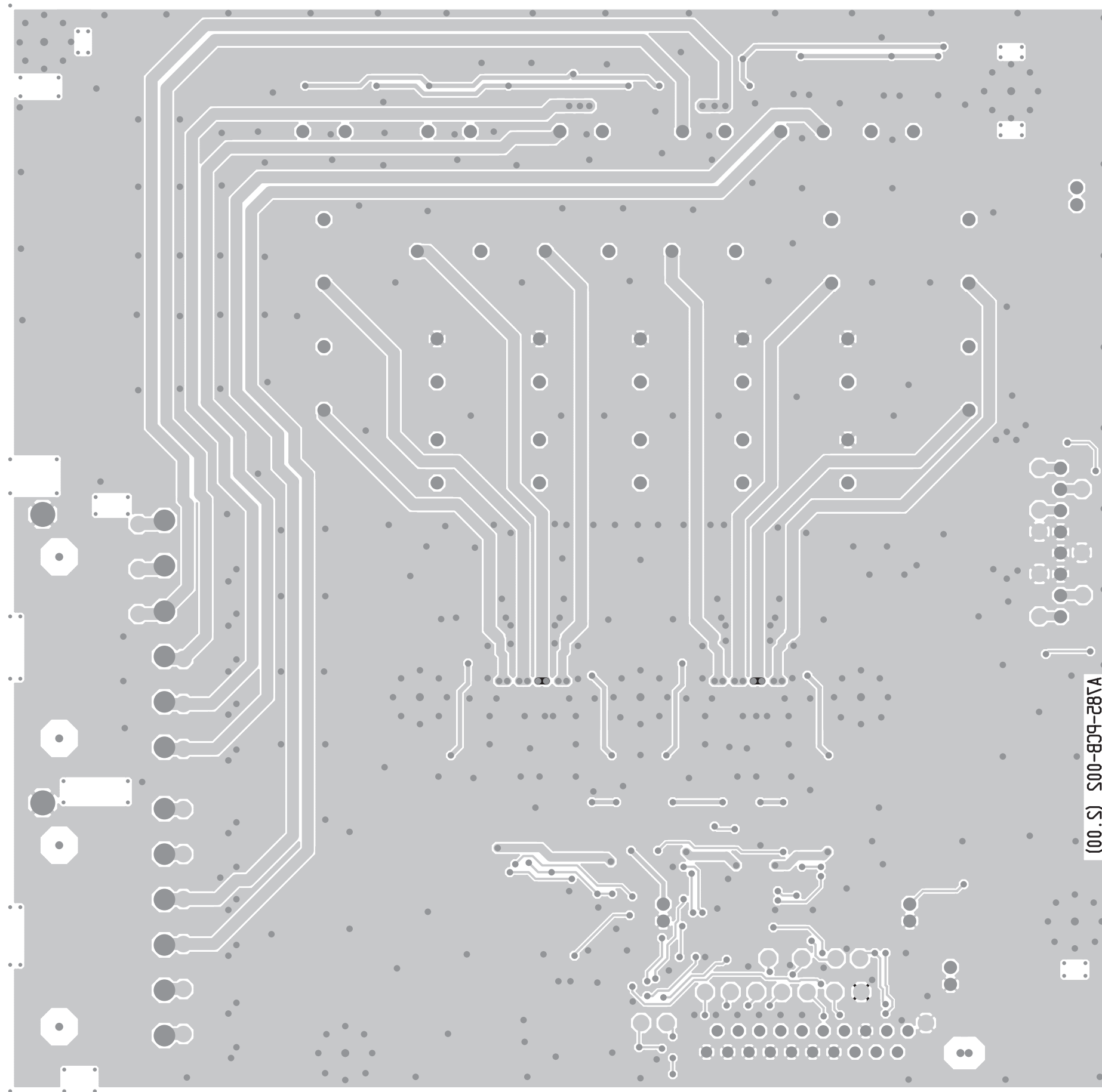



9. Exploded View of the Set

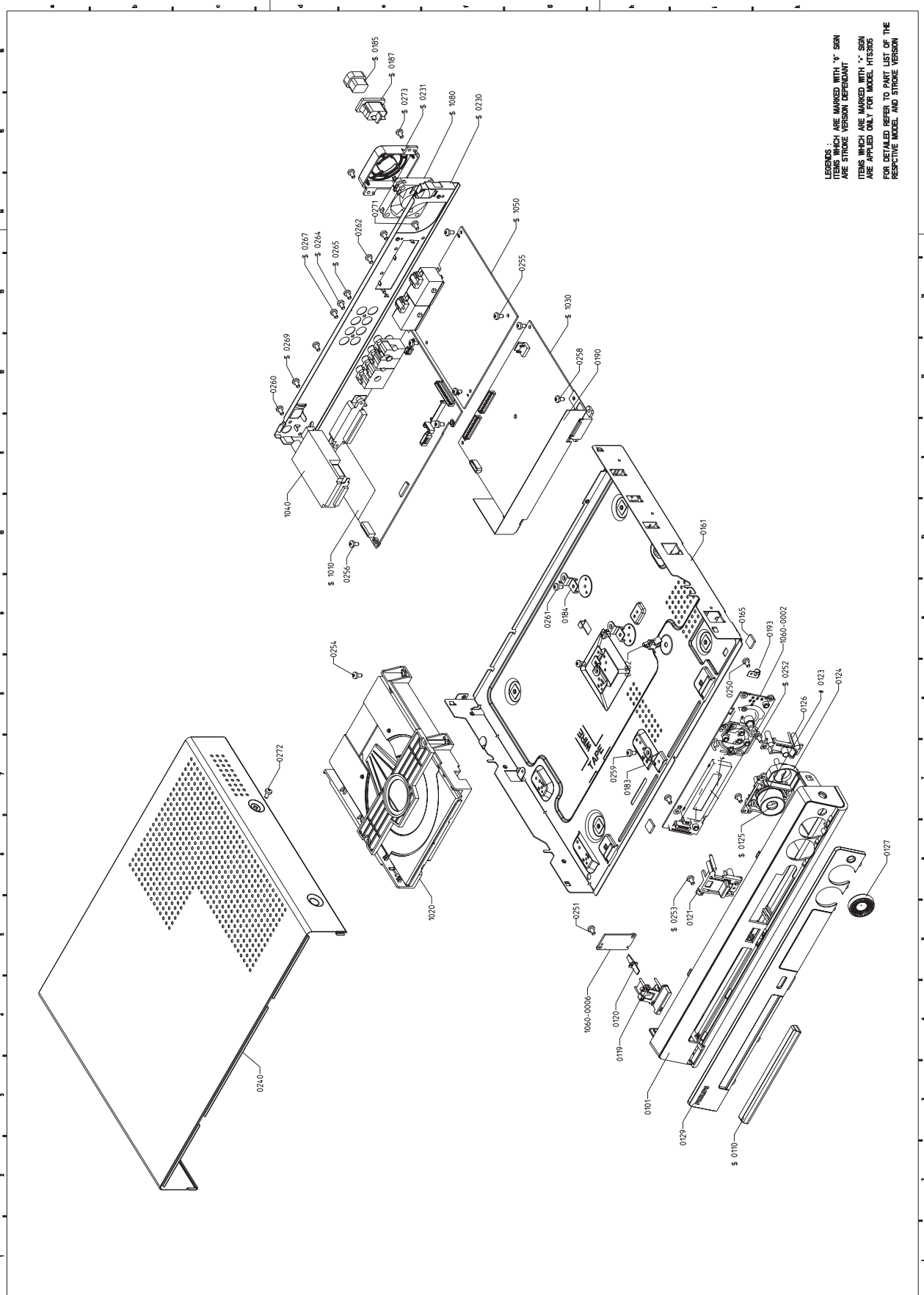



Figure 9-1

HTS3100/05/12/51/93/98 MKI &amp; MKII

## MISCELLANEOUS

0127	3139 244 11161	KNOB VOLUME HTS3100 PNT	<b>BOX SPK ASSY SW-3100 P</b> /51, /93, /98 only
0151	2422 549 00493	DVD LOADER WXD-8829(Y) B	
0152	2422 549 00629	DVD MECHANISM KHM-313AAA Y	9965 000 34996 SW3100 SUBWOOFER BOX
0325	3139 247 12661	BOX SPK ASSY SW-3100 E /05, /12 only	9965 000 34997 RUBBER FOOT SW 9965 000 34998 CABLE A,SSY 5.3M PURPLE SMK
0326	3139 247 12681	BOX SPK ASSY CS-3100 E /05, /12 only	
0333	2422 549 00901	REMOTE CONTR HTS3100-KOK B	<b>BOX SPK ASSY CS-3100 P</b> /51, /93, /98 only
0336	2422 070 98236	MAINSCORD UK 5A 1M8 VH BK B /05 only	9965 000 34983 SPEAKER BOX FRONT-L 9965 000 34984 SPEAKER BOX FRONT-R 9965 000 34985 SPEAKER BOX REAR-L 9965 000 34986 SPEAKER BOX REAR-R 9965 000 34987 CABLE A'SSY 5.2M WHITE SMK 9965 000 34988 CABLE A'SSY 5.2M RED SMK 9965 000 34989 CABLE A'SSY 5.2M BLUE SMK 9965 000 34990 CABLE A,SSY 5.2M GREY SMK 9965 000 34991 RUBBER FOOT 58.5LX5.5WX3T 9965 000 34992 RUBBER FOOT 24LX6WX1T ( L ) 9965 000 34993 SPEAKER BOX CENTER 9965 000 34994 CABLE A'SSY 5.2M GREEN SMK 9965 000 34995 RUBBER FOOT 39.5LX5.5WX2T
0336	4822 321 11499	 MAINSCORD 2.0M - EU /12, /51, /98 only	
0336	2422 070 98232	 MAINSCORD CHN 6A 1M8 VH BK B /93 only	
0340	2422 076 00662	CBLE CINCH 1M7 CINCH 1P YE B /51, /93, /98 only	
0342	2422 076 00468	CBLE SCART 1M1 SCART 21P BK B /05, /12 only	
1010	3139 248 87481	PCBAS MONO HTS3100 EU /05, /12 only	
1010	3139 248 87451	PCBAS MONO HTS3100 ROW /51, /93, /98 only	
1030	3139 247 12511	PSU 06T101 EU AC8080 LF (PIE) /05, /12, /51 only	
1030	3139 247 12501	PSU 06T101 WR AC8082 LF (PIE) /93, /98 only	
1040	2422 542 00031	TUN A F ENG07806QRF EUR B /05, /12, /51 only	
1040	2422 542 00032	TUN A F ENG06806QRF USA B /93, /98 only	
1050	3139 247 12701	MODULE AMP-05-01B 200W	
1060	3139 248 87461	PCBAS FRONT HTS3100 EU /05, /12 only	
1060	3139 248 87731	PCBAS FRONT HTS3100 ROW /51, /93, /98 only	
1070	3139 248 87561	PCBA MONO II HTS3100 EU	
1101	3139 241 00341	FFC FOIL 24P/220/24P AD 0.5MMP	
8001	3139 241 01381	FFC FOIL 10P/120/10P AD FOLD	
8005	3139 241 01921	FFC FOIL 20P/080/20P AD	
P001	3143 027 63751	FRAME ASSY HTS3300 MKII /05, /12 only	
P002	3143 027 63971	FRONT ASSY HTS3100/12 /05, /12 only	
P001	3141 079 36081	FRAME ASSY HTS3100 /51, /93, /98 only	
P002	3141 079 36021	FRONT CAB ASSY HTS3100 ROW /51, /93, /98 only	

## 10 REVISION LIST

### 10.1 Manual 3139 785 31871

#### 1. Additional of HTS3100/75

2. Additional of schematic diagram (point 2) in page 21 of document.

3. Additional of HTS3100/75 for Reprogramming of DVD version Matrix in page 15 of documents.

4. Revise of spare parts list for HTS3100/75 Monoboard MKII.

5. Include Monoboard Blockdiagram.